

Features
<ul style="list-style-type: none"> <li>±25ppm (Frequency Stability) Available</li> <li>Ceramic Package 4 Pad</li> <li>CMOS</li> <li>Programmed Oscillator</li> <li>Tape and Reel</li> </ul>

Applications
<ul style="list-style-type: none"> <li>Micro Processors</li> <li>FPGA</li> <li>Storage Area/Networking</li> <li>Digital Video</li> <li>Portable Computers</li> </ul>

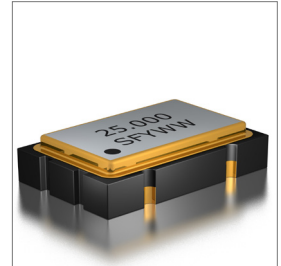

**Part Numbering Guide**

**SQC 75 C 3 A 48 1 - 25.000M**

**SUNTSU QUICK TURN OSC**

7.0mm x 5.0mm

CMOS

**SUPPLY VOLTAGE**  
3 : 3.3V±5%  
5 : 5.0V±5%

**FREQUENCY STABILITY**  
A : ±50ppm  
B : ±30ppm  
C : ±25ppm  
\*D : ±20ppm

**OPERATING TEMPERATURE RANGE**  
07 : 0°C - +70°C  
16 : -10°C - +60°C  
17 : -10°C - +70°C  
27 : -20°C - +70°C  
38 : -30°C - +85°C  
48 : -40°C - +85°C

**FREQUENCY**  
MHz

**TRI-STATE (ENABLE/DISABLE)**  
BLANK : NO CONNECTION  
1 : Pin 1

Cage Code : 4GUT4  
To customize your parameters, contact a Suntsu representative.  
\* For Frequency stability option D, contact a Suntsu representative.

Electrical Parameters	Units	Minimum	Typical	Maximum	Remarks
Frequency Range	MHz	1		133	
Frequency Stability (Includes Initial Tolerance at 25°C, Frequency Stability over Operating Temperature, Output Load Change, Supply Voltage Change, and First Year Aging at 25°C.)	ppm	-20		+20	See part numbering guide for options
Operating Temperature	°C	-40		+85	See part numbering guide for options
Storage Temperature	°C	-55		+125	
Supply Voltage (V <sub>DD</sub> ) - 3.3V option	V	3.135	3.3	3.465	
Supply Voltage (V <sub>DD</sub> ) - 5.0V option	V	4.750	5.0	5.250	
Current (I <sub>DD</sub> ) - 3.3V option	mA			25	
Current (I <sub>DD</sub> ) - 5.0V option	mA			45	
Output Load (CMOS)	pF			15	
Output Logic Levels High (V <sub>OH</sub> )	V	0.9*V <sub>DD</sub>			
Output Logic Levels Low (V <sub>OL</sub> )	V			0.1*V <sub>DD</sub>	
Rise (TR) and Fall (TF) Time	ns			4	
Symmetry (Duty Cycle)	%	45	50	55	
Tri-State Input Voltage(3.3V) - Enable	V	0.7*V <sub>DD</sub>			No Connection
Tri-State Input Voltage(3.3V) - Disable	V			0.3*V <sub>DD</sub>	
Tri-State Input Voltage(5.0V) - Enable	V	2.0			No Connection
Tri-State Input Voltage(5.0V) - Disable	V			0.8	
Start-Up Time	ms			10	
Phase Jitter (12kHz ~ 20MHz)	ps		50	100	

**Outline Drawing & Land Pattern**

All dimensions are in millimeters (mm) unless otherwise noted. Drawings are not to scale.

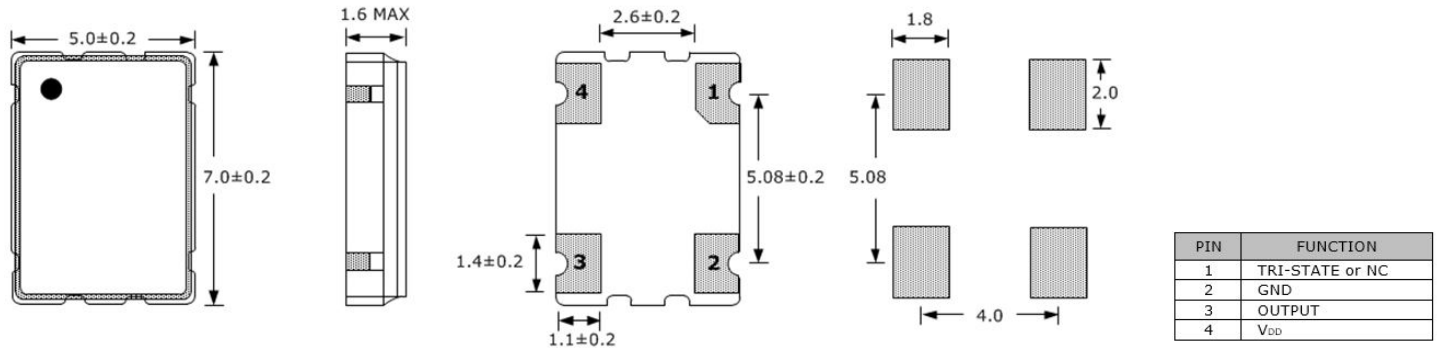

**Test Circuit (CMOS)**

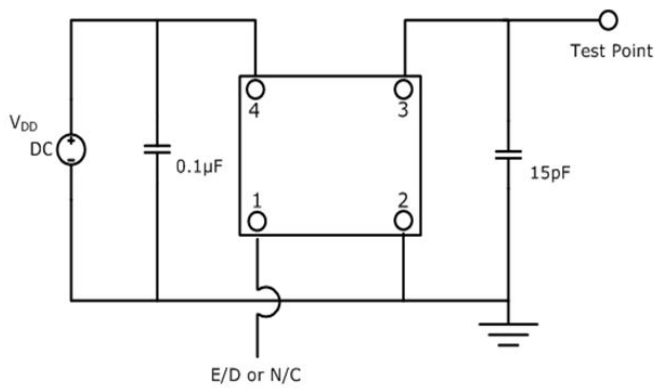

**Waveform (CMOS)**

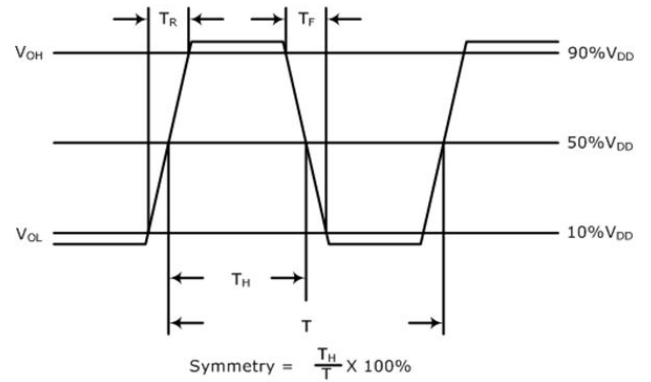

**Typical Phase Noise Performance (Measured By Agilent E5052A)**

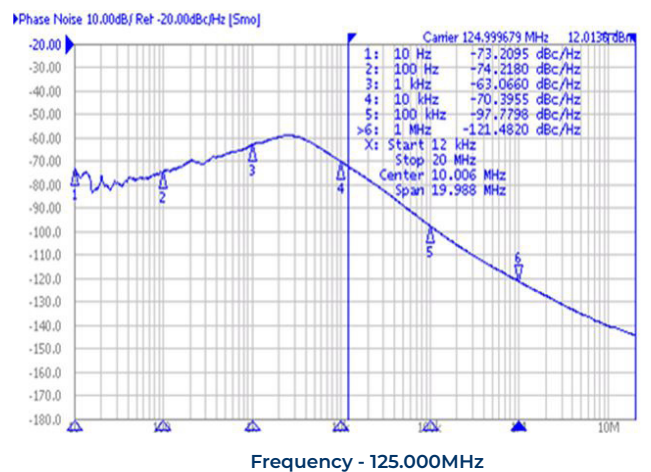
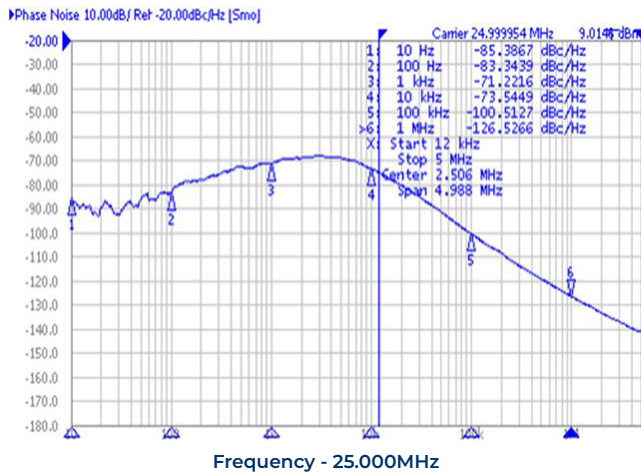

### Typical Jitter Performance (Measured By Agilent E5052A)

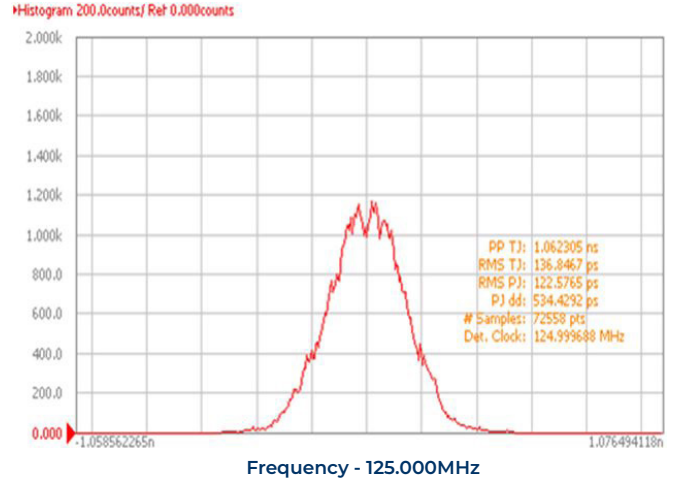
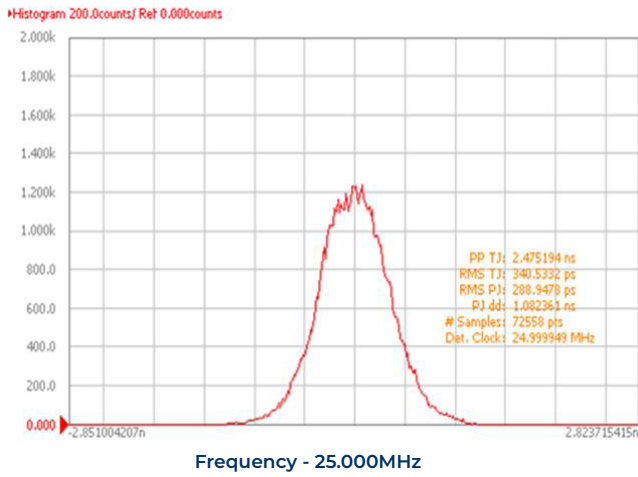

### Reflow Profile

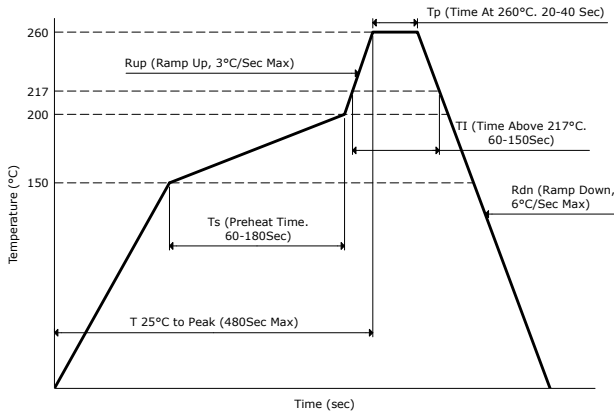

### Part Marking

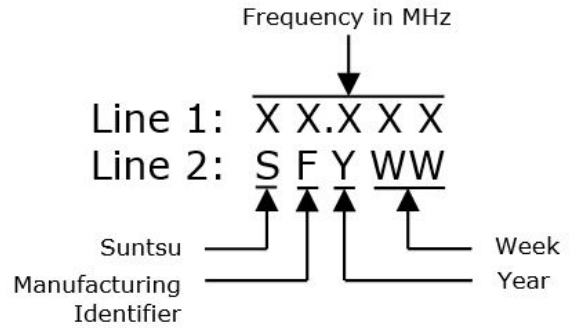

### Tape And Reel Dimensions

All dimensions are in millimeters (mm) unless otherwise noted. Drawings are not to scale.

1,000pcs/Reel

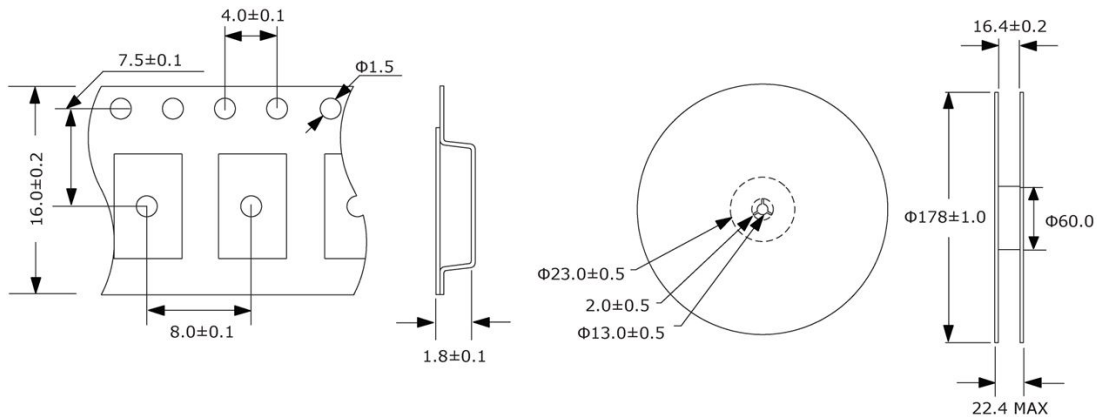

Environmental Specifications		Mechanical Specifications	
Temperature Cycling	MIL-STD-883, Method 1010, Condition B	Mechanical Shock	MIL-STD-202, Method 213, Condition B
Fine Leak Test	MIL-STD-883, Method 1014, Condition A	Vibration	MIL-STD-883, Method 2007, Condition A
Gross Leak Test	MIL-STD-883, Method 1014, Condition C	Moisture Resistance	MIL-STD-883, Method 1004
Solderability	MIL-STD-883, Method 2003	Resistance to Solvents	MIL-STD-202, Method 215
Moisture Sensitivity	J-STD-020, MSL 1	Resistance to Soldering Heat	MIL-STD-202, Method 210, Condition K