

Features
<ul style="list-style-type: none"> ±20ppm (Frequency Stability) Available Ceramic Package LVPECL Ultra Low Phase Jitter Tape and Reel

Applications
<ul style="list-style-type: none"> Fiber Channel Gigabit Ethernet PCI Express

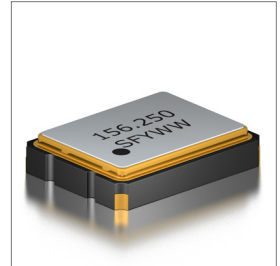

Part Numbering Guide

SUO 32 P 3 A 48 1 - 156.250M

SUNTSU ULTRA LOW JITTER OSC
3.2mm x 2.5mm

LVPECL

SUPPLY VOLTAGE
3 : 3.3V±5%

FREQUENCY STABILITY
A : ±50ppm
B : ±30ppm
C : ±25ppm
*D : ±20ppm

OPERATING TEMPERATURE RANGE
07 : 0°C - +70°C
16 : -10°C - +60°C
17 : -10°C - +70°C
27 : -20°C - +70°C
38 : -30°C - +85°C
48 : -40°C - +85°C

FREQUENCY MHz
TRI-STATE (ENABLE/DISABLE)
BLANK : No E/D
1 : Pin 1

RoHS COMPLIANT

Cage Code : 4GUT4
To customize your parameters, contact a Suntsu representative.
* For Frequency stability option D, contact a Suntsu representative.

Electrical Parameters	Units	Minimum	Typical	Maximum	Remarks
Frequency Range	MHz	80		170	
Frequency Stability (Includes Initial Tolerance at 25°C, Frequency Stability over Operating Temperature, Output Load Change, Supply Voltage Change, and First Year Aging at 25°C.)	ppm	-20		+20	See part numbering guide for options
Operating Temperature	°C	-40		+85	See part numbering guide for options
Storage Temperature	°C	-55		+125	
Supply Voltage (V _{DD})	V	3.125	3.3	3.465	
Current (I _{DD})	mA			70	
Output Load (LVPECL)	Ω			50	50 Ω into V _{DD} -2.0V _{DC}
Output Logic Levels High (V _{OH})	V	2.215		2.420	
Output Logic Levels Low (V _{OL})	V	1.470		1.745	
Rise (TR) and Fall (TF) Time	ns		0.4	0.6	Measured at 20% to 80% of Waveform
Symmetry (Duty Cycle)	%	45	50	55	
Tri-State Input Voltage - Enable	V	0.7*V _{DD}			No Connection
Tri-State Input Voltage - Disable	V			0.3*V _{DD}	
Start-Up Time	ms			5	
Phase Jitter (12kHz ~ 20MHz)	ps		0.077	0.1	150MHz - 170MHz
Phase Jitter (12kHz ~ 20MHz)	ps		0.13	0.2	80MHz - 149MHz

Outline Drawing & Land Pattern

All dimensions are in millimeters (mm) unless otherwise noted. Drawings are not to scale.

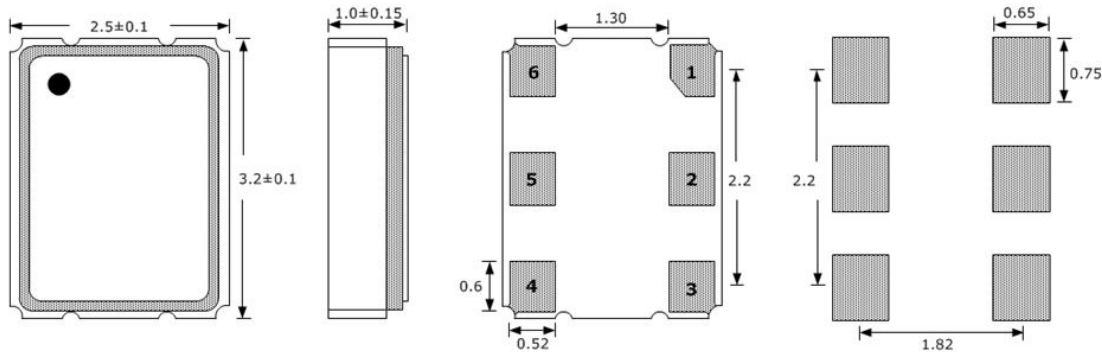

PIN	FUNCTION
1	TRI-STATE or NC
2	NC
3	GND
4	OUTPUT
5	COMP OUTPUT
6	V _{DD}

Test Circuit (LVPECL)

Waveform (LVPECL)

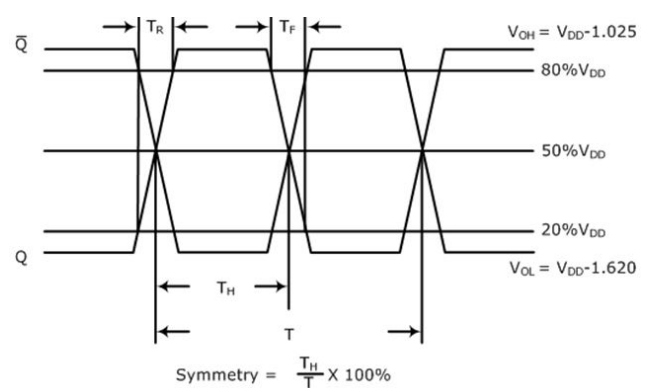
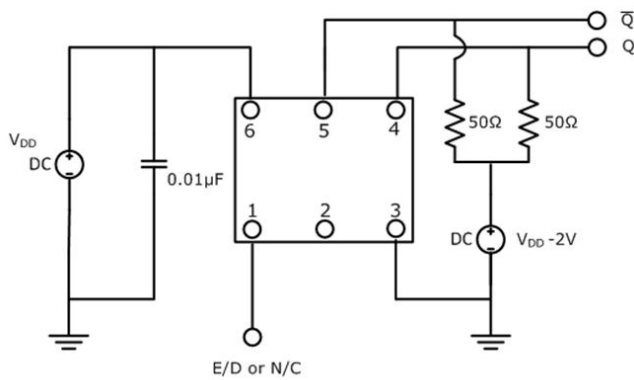

Typical Phase Noise Performance (Measured By Agilent E5052A)

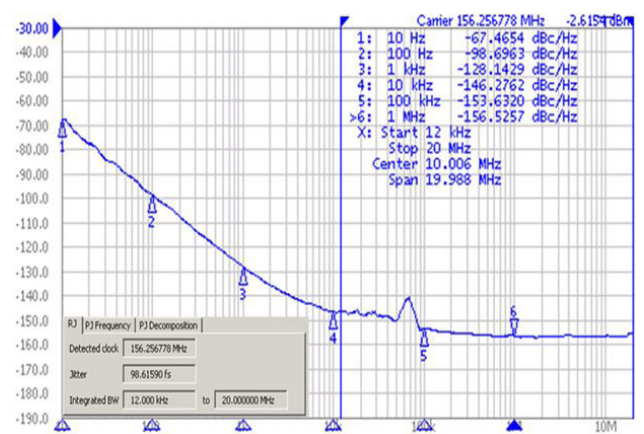
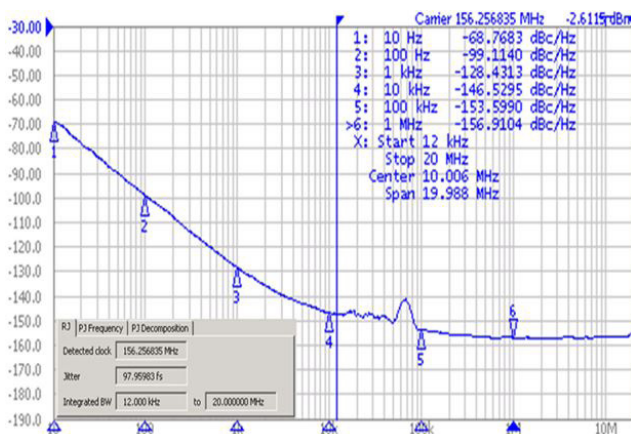

Frequency - 156.250MHz

Frequency - 156.250MHz

Typical Jitter Performance (Measured By Agilent E5052A)

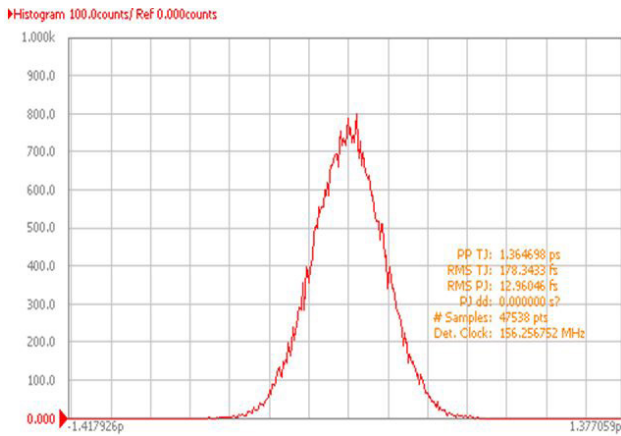

Frequency - 156.250MHz

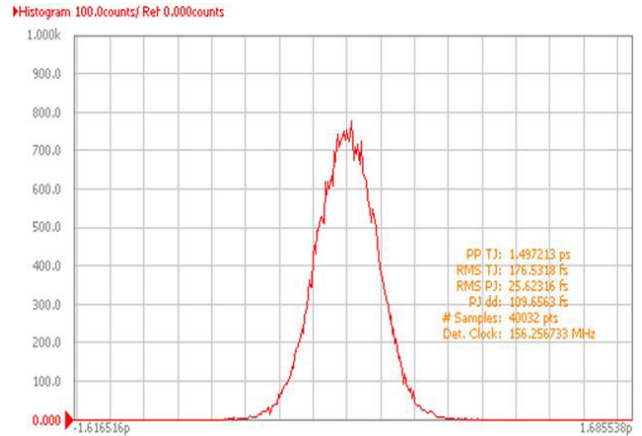

Frequency - 156.250MHz

Reflow Profile

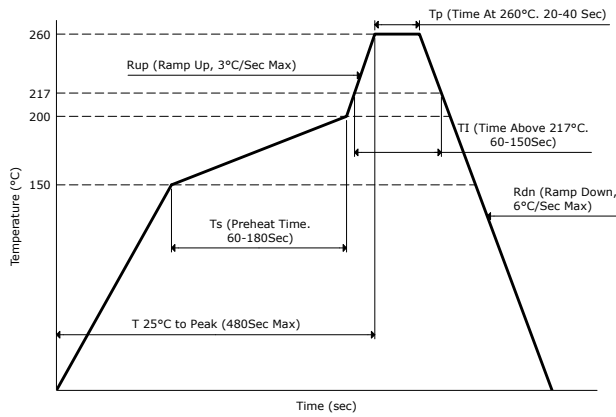

Part Marking

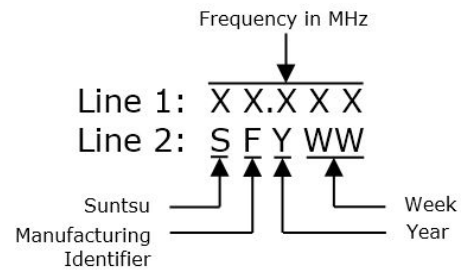

Tape And Reel Dimensions

All dimensions are in millimeters (mm) unless otherwise noted. Drawings are not to scale.

3,000pcs/Reel

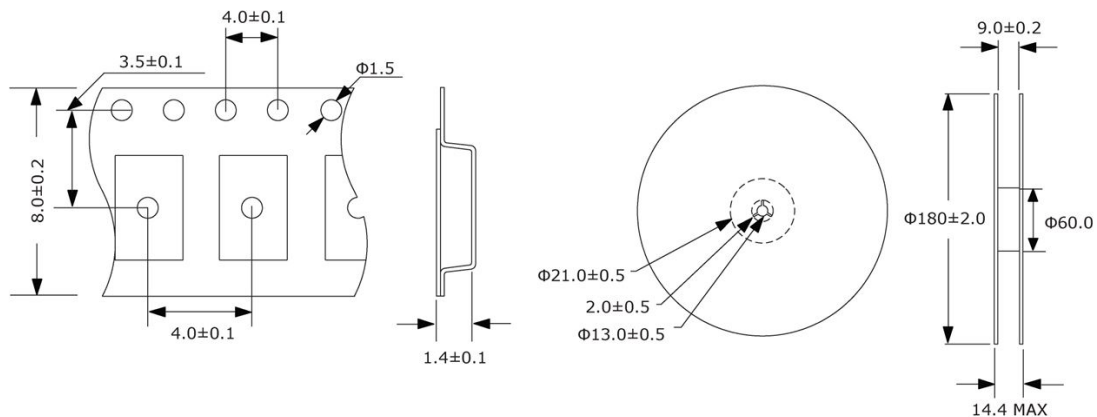

Environmental Specifications		Mechanical Specifications	
Temperature Cycling	MIL-STD-883, Method 1010, Condition B	Mechanical Shock	MIL-STD-202, Method 213, Condition B
Fine Leak Test	MIL-STD-883, Method 1014, Condition A	Vibration	MIL-STD-883, Method 2007, Condition A
Gross Leak Test	MIL-STD-883, Method 1014, Condition C	Moisture Resistance	MIL-STD-883, Method 1004
Solderability	MIL-STD-883, Method 2003	Resistance to Solvents	MIL-STD-202, Method 215
Moisture Sensitivity	J-STD-020, MSL 1	Resistance to Soldering Heat	MIL-STD-202, Method 210, Condition K