

Features
<ul style="list-style-type: none"> ±20ppm (Frequency Stability) Available Ceramic Package LVDS Ultra Low Phase Jitter Tape and Reel

Applications
<ul style="list-style-type: none"> Fiber Channel Gigabit Ethernet PCI Express Storage Area Networking Telecom COTS

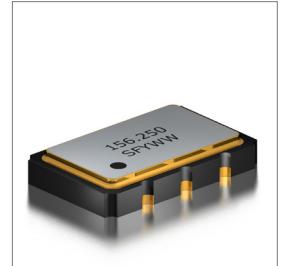

Part Numbering Guide

SUO 53 L 3 A 48 1 - 156.250M

SUNTSU ULTRA LOW JITTER OSC
5.0mm x 3.2mm

LVDS

SUPPLY VOLTAGE
3 : 3.3V±5%

FREQUENCY STABILITY
A : ±50ppm
B : ±30ppm
C : ±25ppm
*D : ±20ppm

OPERATING TEMPERATURE RANGE
07 : 0°C - +70°C
16 : -10°C - +60°C
17 : -10°C - +70°C
27 : -20°C - +70°C
38 : -30°C - +85°C
48 : -40°C - +85°C

FREQUENCY
MHz

TRI-STATE (ENABLE/DISABLE)
BLANK : NO E/D
1 : Pin 1

RoHS COMPLIANT

Cage Code : 4GUT4
To customize your parameters, contact a Suntsu representative.
* For Frequency stability option D, contact a Suntsu representative.

Electrical Parameters	Units	Minimum	Typical	Maximum	Remarks
Frequency Range	MHz	80		170	
Frequency Stability (Includes Initial Tolerance at 25°C, Frequency Stability over Operating Temperature, Output Load Change, Supply Voltage Change, and First Year Aging at 25°C.)	ppm	-20		+20	See part numbering guide for options
Operating Temperature	°C	-40		+85	See part numbering guide for options
Storage Temperature	°C	-55		+125	
Supply Voltage (V _{DD})	V	3.135	3.3	3.465	
Current (I _{DD})	mA			65	
Output Load (LVDS)	Ω			100	
Output Logic Levels High (V _{OH})	V		1.43	1.6	
Output Logic Levels Low (V _{OL})	V	0.9	1.1		
Differential Output Voltage (V _{OD})	mV	247	330	454	
Differential Output Error (ρV _{OD})	mV	-50		50	
Offset Voltage (V _{OS})	V	1.125	1.250	1.375	
Offset Error (ρV _{OS})	mV	-50		50	
Rise (TR) and Fall (TF) Time	ns		0.5	1.0	
Symmetry (Duty Cycle)	%	45	50	55	
Tri-State Input Voltage - Enable	V	0.7*V _{DD}			No Connection
Tri-State Input Voltage - Disable	V			0.3*V _{DD}	
Start-Up Time	ms			10	
Phase Jitter (12kHz ~ 20MHz)	ps		0.077	0.1	150MHz - 170MHz
Phase Jitter (12kHz ~ 20MHz)	ps		0.13	0.2	80MHz - 149MHz

Outline Drawing & Land Pattern

All dimensions are in millimeters (mm) unless otherwise noted. Drawings are not to scale.

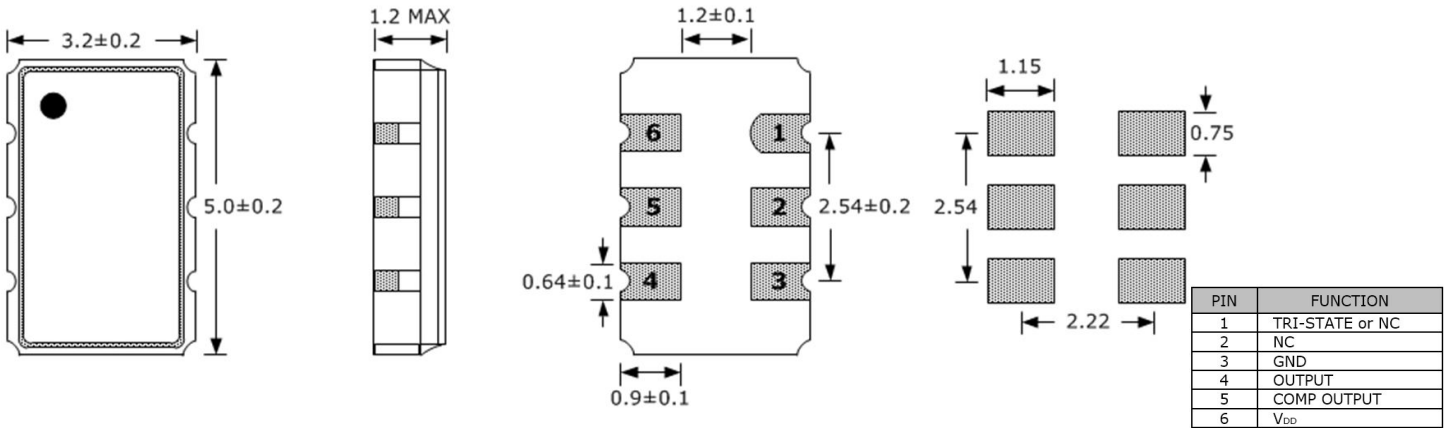

Test Circuit (LVDS)

Waveform (LVDS)

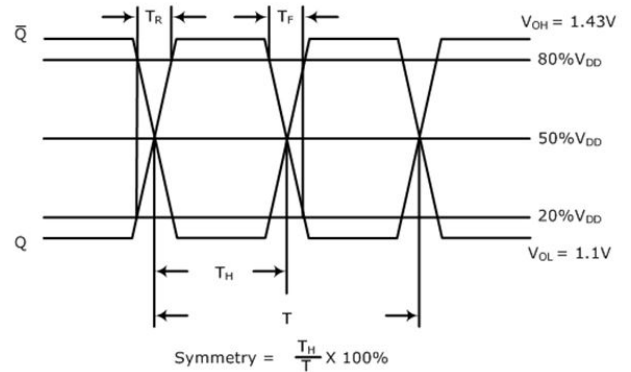
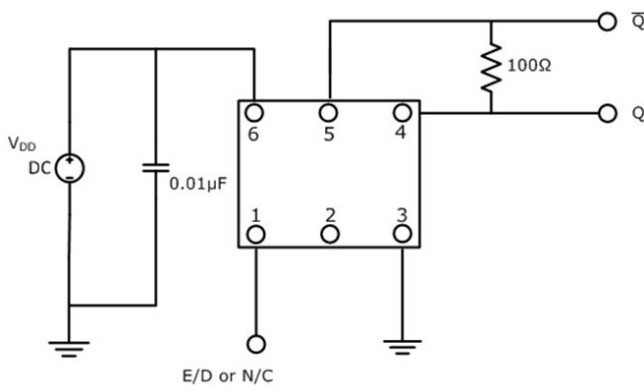

Typical Phase Noise Performance (Measured By Agilent E5052A)

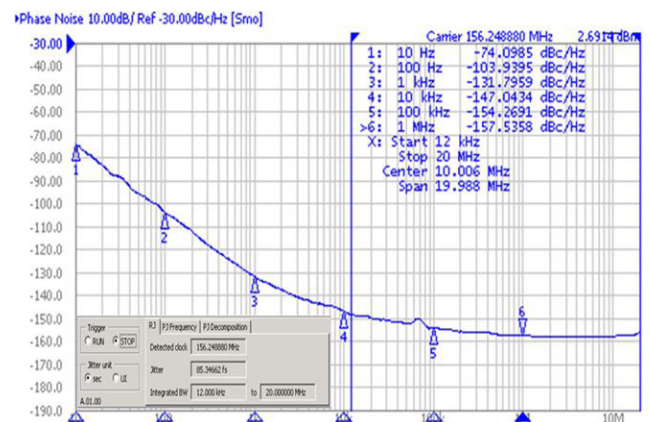
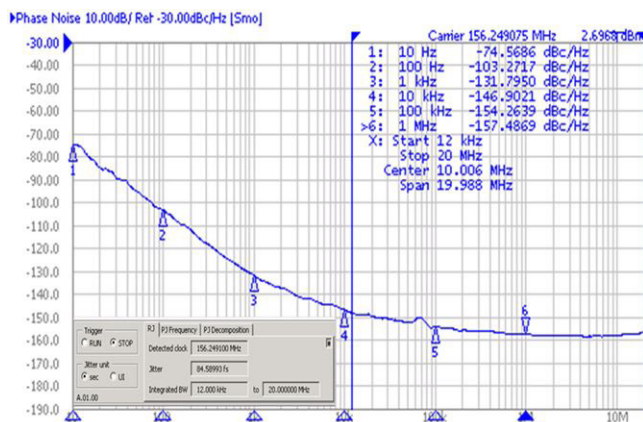

Typical Jitter Performance (Measured By Agilent E5052A)

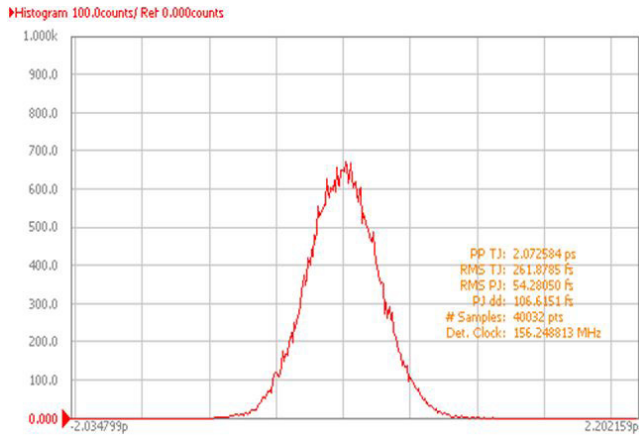

Frequency - 156.250MHz

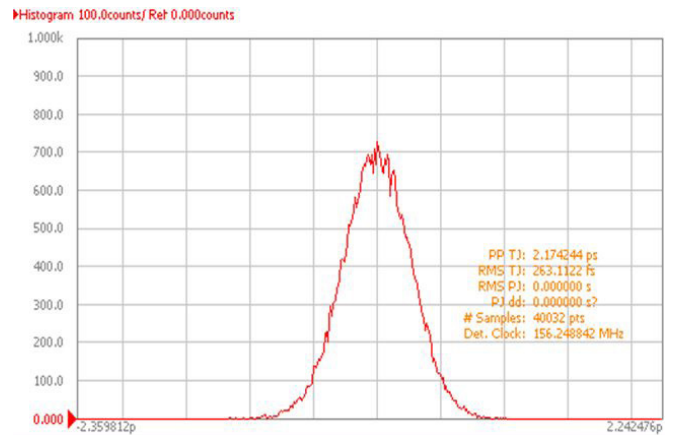

Frequency - 156.250MHz

Reflow Profile

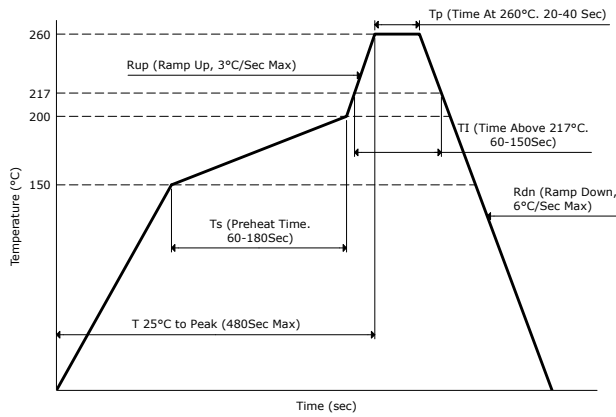

Part Marking

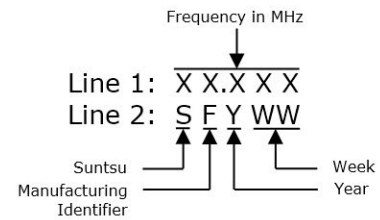

Tape And Reel Dimensions

All dimensions are in millimeters (mm) unless otherwise noted. Drawings are not to scale.

1,000pcs/Reel

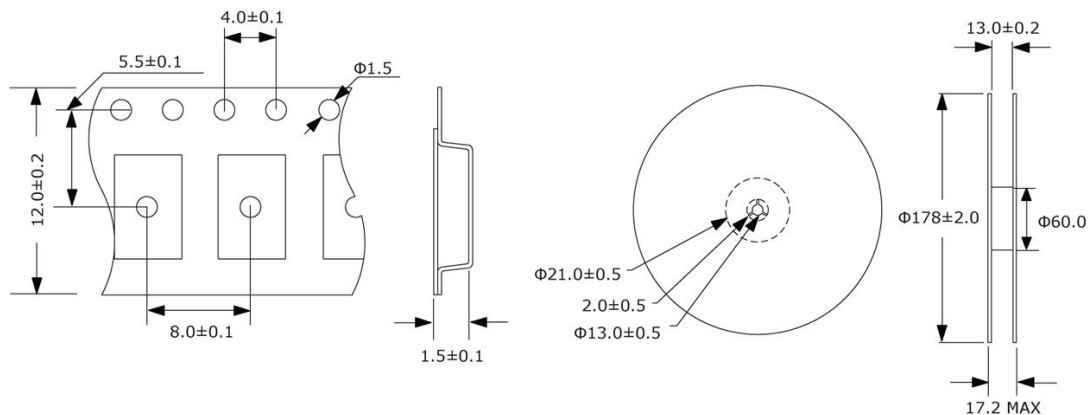

Environmental Specifications		Mechanical Specifications	
Temperature Cycling	MIL-STD-883, Method 1010, Condition B	Mechanical Shock	MIL-STD-202, Method 213, Condition B
Fine Leak Test	MIL-STD-883, Method 1014, Condition A	Vibration	MIL-STD-883, Method 2007, Condition A
Gross Leak Test	MIL-STD-883, Method 1014, Condition C	Moisture Resistance	MIL-STD-883, Method 1004
Solderability	MIL-STD-883, Method 2003	Resistance to Solvents	MIL-STD-202, Method 215
Moisture Sensitivity	J-STD-020, MSL 1	Resistance to Soldering Heat	MIL-STD-202, Method 210, Condition K