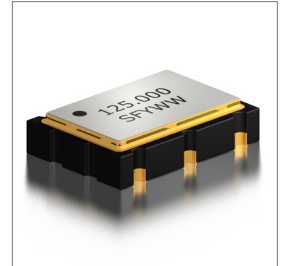
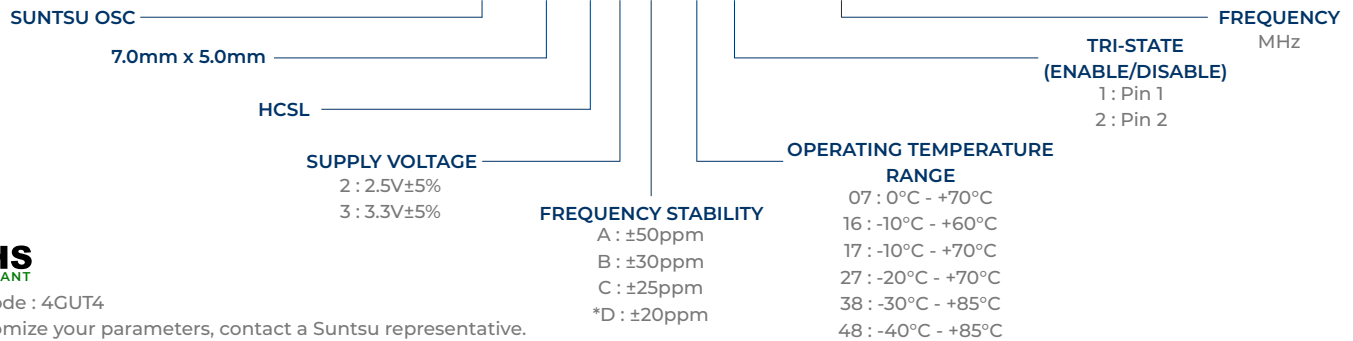

Features
<ul style="list-style-type: none"> <li>±20ppm (Frequency Stability) Available</li> <li>Ceramic Package</li> <li>HCSL</li> <li>Tape and Reel</li> </ul>

Applications
<ul style="list-style-type: none"> <li>Fiber Channel</li> <li>Gigabit Ethernet</li> <li>PCI Express</li> </ul>

**Part Numbering Guide**
**SXO 75 H 3 A 48 1 - 125.000M**

Cage Code : 4GUT4

To customize your parameters, contact a Suntsu representative.

\* For Frequency stability option D, contact a Suntsu representative.

Electrical Parameters	Units	Minimum	Typical	Maximum	Remarks
Frequency Range	MHz	100		125	
Frequency Stability (Includes Initial Tolerance at 25°C, Frequency Stability over Operating Temperature, Output Load Change, Supply Voltage Change, and First Year Aging at 25°C.)	ppm	-20		+20	See part numbering guide for options
Operating Temperature	°C	-40		+85	See part numbering guide for options
Storage Temperature	°C	-55		+125	
Supply Voltage (V <sub>DD</sub> ) - 2.5V option	V	2.375	2.5	2.625	
Supply Voltage (V <sub>DD</sub> ) - 3.3V option	V	3.125	3.3	3.465	
Current (I <sub>DD</sub> ) - 2.5V option	mA			60	
Current (I <sub>DD</sub> ) - 3.3V option	mA			80	
Output Load (HCSL)	Ω			50	50 Ω into V <sub>DD</sub> -2.0V <sub>DC</sub>
Output Logic Levels High (V <sub>OH</sub> )	mV	600		900	
Output Logic Levels Low (V <sub>OL</sub> )	V	0		50	
Rise (TR) and Fall (TF) Time	ns		0.4	0.7	
Symmetry (Duty Cycle)	%	45	50	55	
Tri-State Input Voltage - Enable	V	0.7*V <sub>DD</sub>			No Connection
Tri-State Input Voltage - Disable	V			0.3*V <sub>DD</sub>	
Start-Up Time	ms			10	
Phase Jitter (12kHz ~ 20MHz)	ps		0.5	1	

**Outline Drawing & Land Pattern**

All dimensions are in millimeters (mm) unless otherwise noted. Drawings are not to scale.

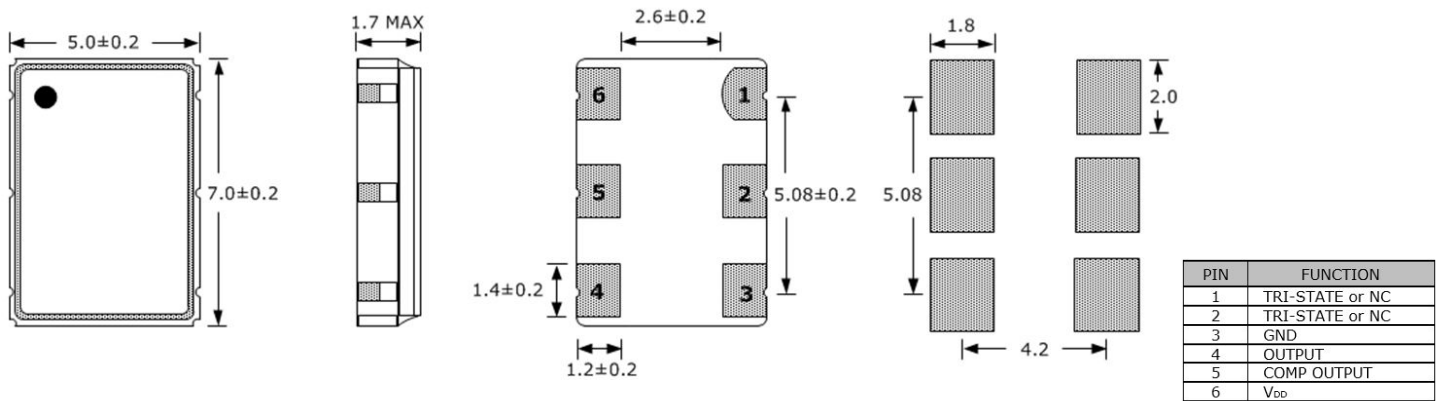
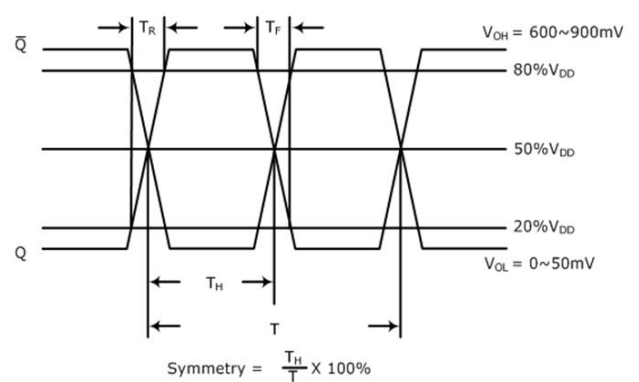
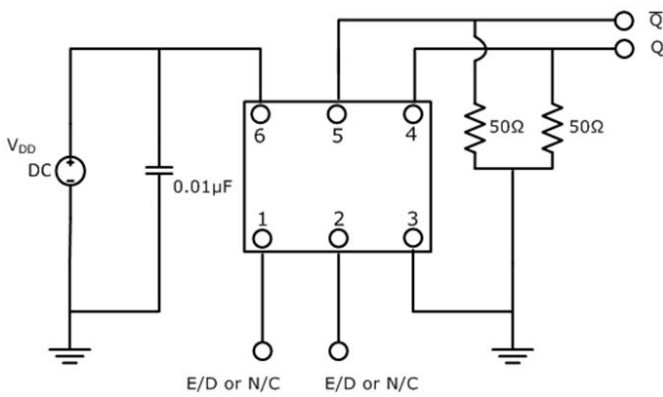
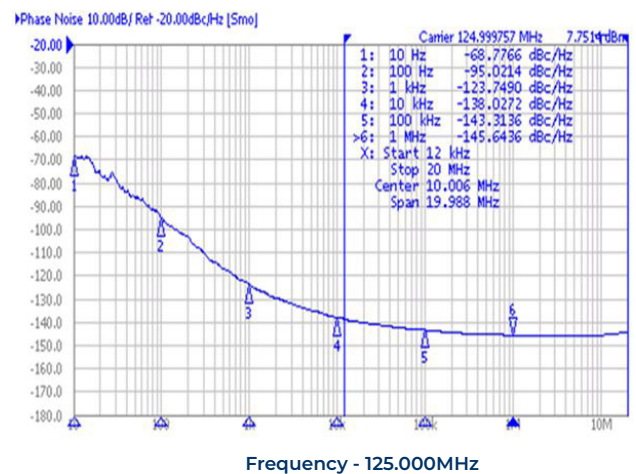
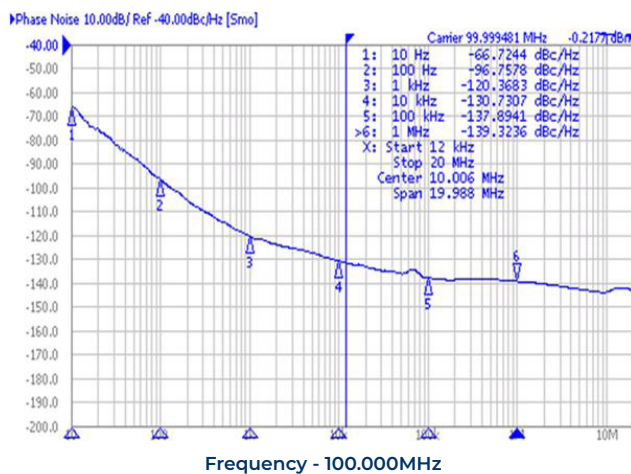
**Test Circuit (HCSL)**
**Waveform (HCSL)**

**Typical Phase Noise Performance (Measured By Agilent E5052A)**

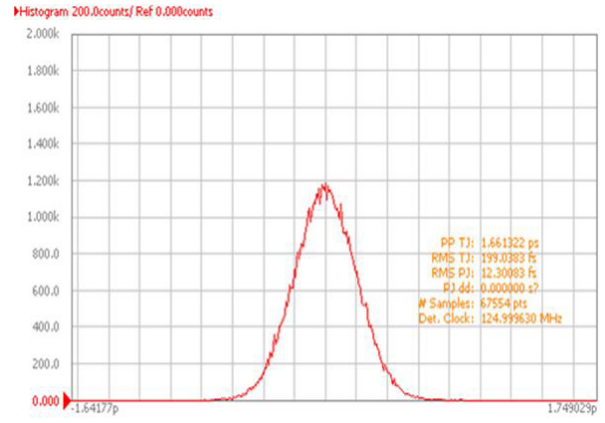
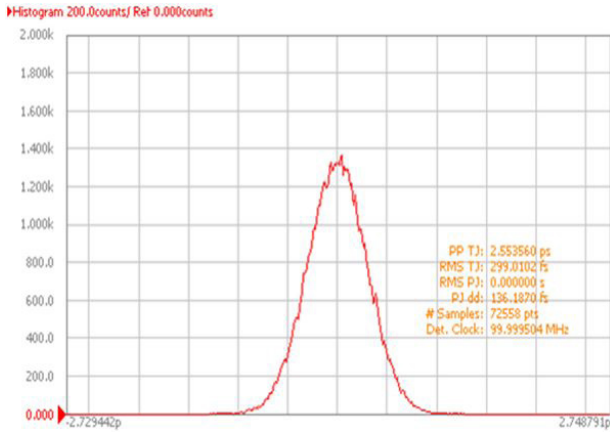
Typical Jitter Performance (Measured By Agilent E5052A)

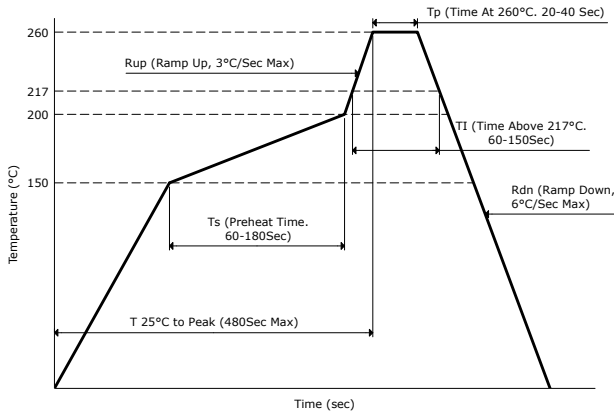

Reflow Profile



Part Marking

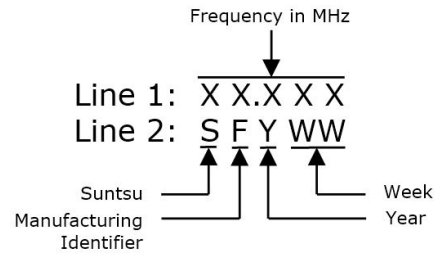

Tape And Reel Dimensions

All dimensions are in millimeters (mm) unless otherwise noted. Drawings are not to scale.

1,000pcs/Reel

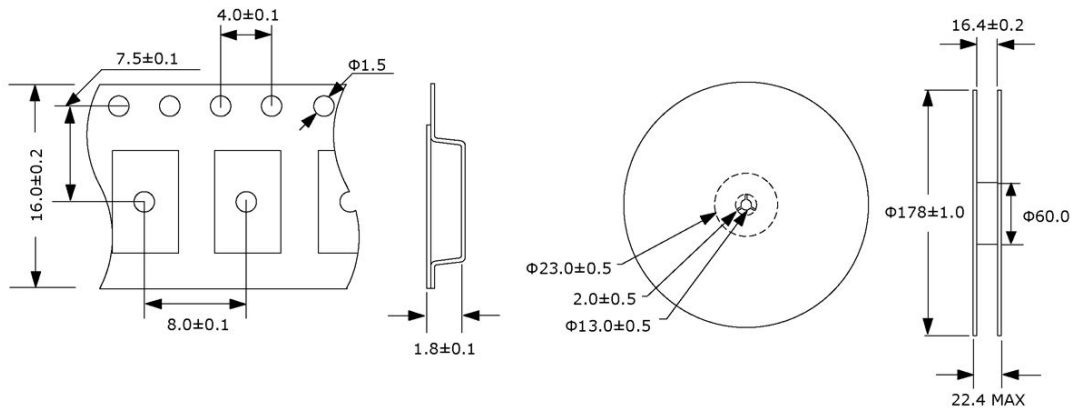

Environmental Specifications		Mechanical Specifications	
Temperature Cycling	MIL-STD-883, Method 1010, Condition B	Mechanical Shock	MIL-STD-202, Method 213, Condition B
Fine Leak Test	MIL-STD-883, Method 1014, Condition A	Vibration	MIL-STD-883, Method 2007, Condition A
Gross Leak Test	MIL-STD-883, Method 1014, Condition C	Moisture Resistance	MIL-STD-883, Method 1004
Solderability	MIL-STD-883, Method 2003	Resistance to Solvents	MIL-STD-202, Method 215
Moisture Sensitivity	J-STD-020, MSL 1	Resistance to Soldering Heat	MIL-STD-202, Method 210, Condition K