

Features
<ul style="list-style-type: none"> ±10ppm/±10ppm (Tolerance/Stability) Available Glass Sealed AT-Cut Fundamental Tape and Reel

Applications
<ul style="list-style-type: none"> Microprocessors PCMCIA Communication Test Equipment

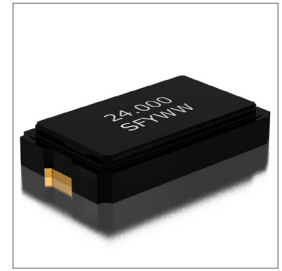

Part Numbering Guide

SXT 8G 2 18 A A 48 T - 24.000M

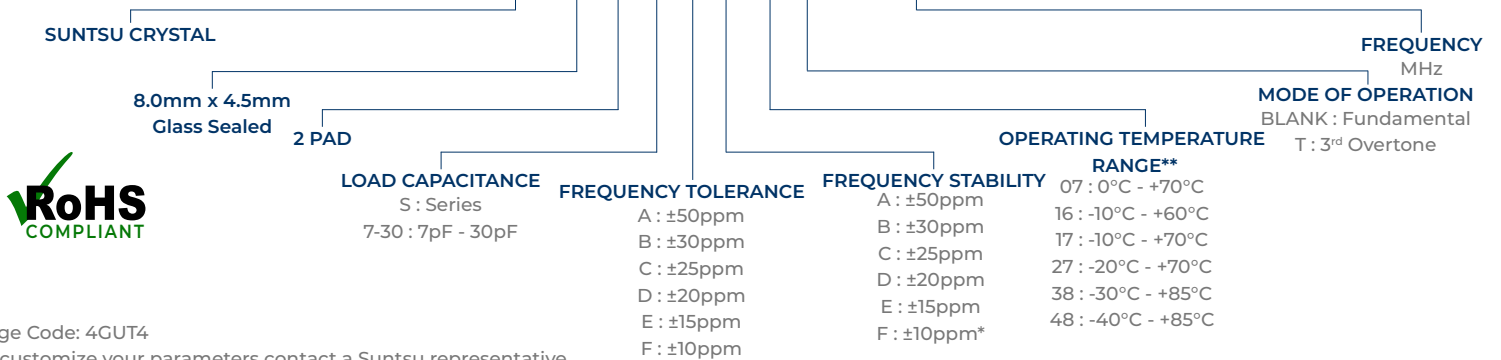

Cage Code: 4GUT4

To customize your parameters contact a Suntsu representative.

* For frequency stability option F contact a Suntsu representative. ** For operating temperatures of -55-125°C a Suntsu representative.

Electrical Parameters	Units	Minimum	Typical	Maximum	Remarks
Frequency Range	MHz	6		40	AT-Cut Fundamental.
Frequency Range	MHz	40		80	3 rd Overtone.
Frequency Tolerance at +25°C	ppm	-10		+10	See part numbering guide for options.
Frequency Stability vs. Op Temp	ppm	-10		+10	First year @ +25°C.
Frequency Stability vs. Aging	ppm	-3		+3	
Operating Temperature	°C	-40		+85	See part numbering guide for options.
Storage Temperature	°C	-40		+125	
Load Capacitance	pF	7		30	See part numbering guide for options.
Shunt Capacitance	pF			7	
Drive Level	µW		100	300	
Insulation Resistance	MΩ	500			@ 100VDC ± 15V.
6.000MHz ~ 9.999MHz	Ω			100	AT-Cut Fundamental
ESR - 10.000MHz ~ 11.999MHz	Ω			50	AT-Cut Fundamental
12.000MHz ~ 40.000MHz	Ω			40	AT-Cut Fundamental
40.000MHz ~ 80.000MHz	Ω			70	3 rd Overtone.

Outline Drawing & Recommended Landed Pattern

All dimensions are in millimeters (mm) unless otherwise noted. Drawings are not to scale.

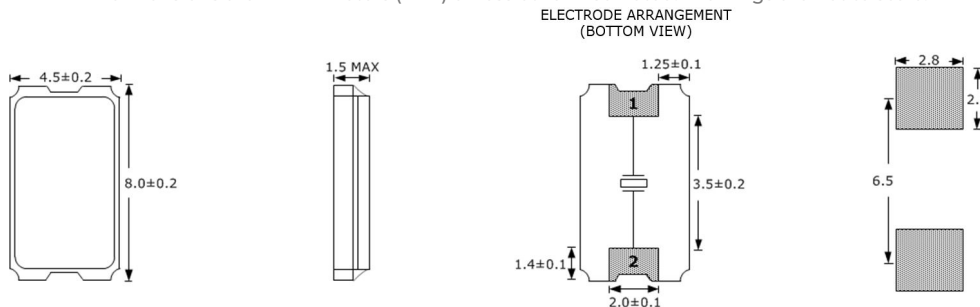

Environmental Specifications		Mechanical Specifications	
Temperature Cycling	MIL-STD-883, Method 1010, Condition B	Mechanical Shock	MIL-STD-202, Method 213, Condition B
Fine Leak Test	MIL-STD-883, Method 1014, Condition A	Vibration	MIL-STD-883, Method 2007, Condition A
Gross Leak Test	MIL-STD-883, Method 1014, Condition C	Resistance to Soldering Heat	MIL-STD-202, Method 210, Condition K
Moisture Resistance	MIL-STD-883, Method 1004	Resistance to Solvents	MIL-STD-202, Method 215
Moisture Sensitivity	J-STD-020, MSL 1	Solderability	MIL-STD-883, Method 2003

