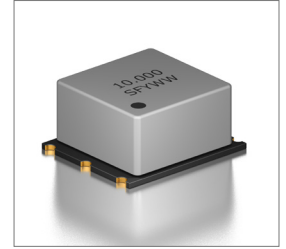

Features

- Stratum 3E
- ± 0.005 ppm Stability
- 10MHz
- Tape & Reel
- MSL : Level 3

Applications

- Si5348/83/84/88/89 Network Synchronizer Clocks
- Si5371/72 Coherent Optics Clocks
- Si5392-97 Jitter Cleaners

Part Numbering Guide

SJX240 - 10.000M



Electrical Parameters	Units	Minimum	Typical	Maximum	Remarks
Frequency	MHz		10.000		
Frequency Tolerance at +25°C	ppm	-2.0		+2.0	
Freq. Stability vs. Op Temp.	ppm	-0.005		+0.005	Ref. to Freq. observed with $f_{ref}=(f_{max}+f_{min})/2$
Freq. Stability vs. Supply Voltage	ppb	-0.2		+0.2	V _{DD} $\pm 5\%$ Change
Freq. Stability vs. Load	ppb	-0.2		+0.2	$\pm 5\%$ Change
Micro jump	ppb	-0.1		+0.1	Continuous testing for 48 hours
Reflow Shift	ppm	-0.2		+0.2	After 24 hour recovery at 25°C 2xreflow
Retrace	ppm	-0.01		+0.01	After 24 hour off at 25°C 15min power on
Short-term Stability Allan Variance	ppb			0.01	
Freq. Stability vs. Aging/Day	ppb	-0.5		+0.5	
Freq. Stability vs. Aging/Year	ppm	-0.05		+0.05	
Operating Temperature	°C	-40		+85	
Storage Temperature	°C	-55		+105	
Supply Voltage (V _{DD}) - 3.3V	V	3.13	3.3	3.47	
Power Consumption At Turn On	mA			1200	
Power Consumption At 25°C	mA			400	
Output Logic (LVTTTL)	pF	13.5	15	16.5	
Output Logic Level - High (V _{OH})	V	2.4			
Output Logic Level - Low (V _{OL})	V			0.4	
Overshoot	%		10		
Rise Time (T _R) And Fall Time (T _F)	ns			5	
Symmetry (Duty Cycle)	%	45	50	55	
Start-Up Time	s			0.5	
Warm-Up Time	Mins			8	Freq. @25°C reference after 1hr
Phase Noise 1Hz Offset	dBc/Hz		-100	-90	
Phase Noise 10Hz Offset	dBc/Hz		-125	-120	
Phase Noise 100Hz Offset	dBc/Hz		-145	-140	
Phase Noise 1kHz Offset	dBc/Hz		-155	-150	
Phase Noise 10kHz Offset	dBc/Hz		-157	-155	
Phase Noise 100kHz Offset	dBc/Hz		-157	-155	
Phase Noise 1MHz Offset	dBc/Hz		-160	-155	
Phase Jitter 12kHz - 5MHz	ps			0.5	
Acceleration sensitivity	ppb/g			4	

Outline Drawing & Land Pattern

All dimensions are in millimeters (mm) unless otherwise noted. Drawings are not to scale.

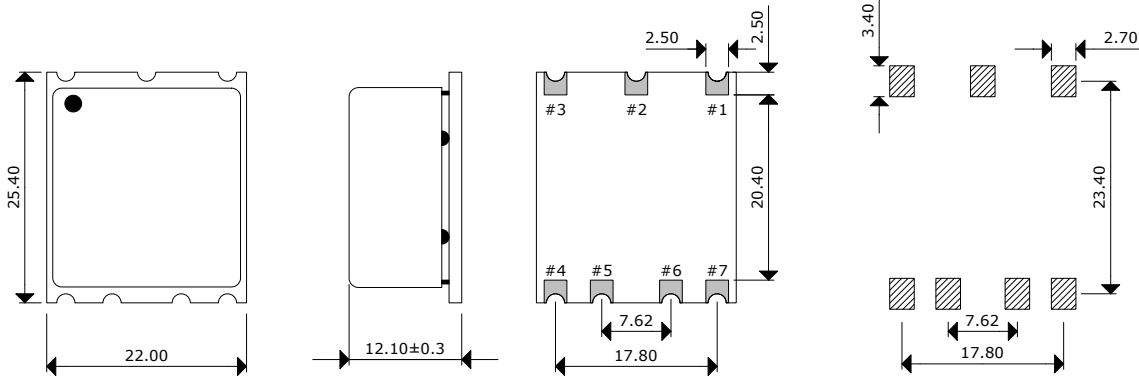

Pin#	Function
1	NC
2	NC
3	V _{DD}
4	OUTPUT
5 & 6	NC
7	GND

Test Circuit (LVTTTL)

Waveform (LVTTTL)

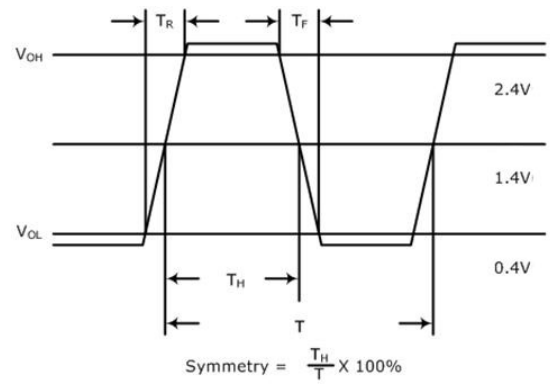
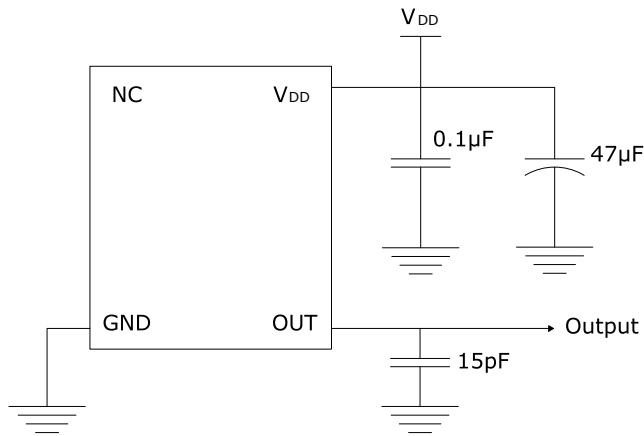

Typical Phase Noise And Jitter Performance (Measured By Agilent E5052B)

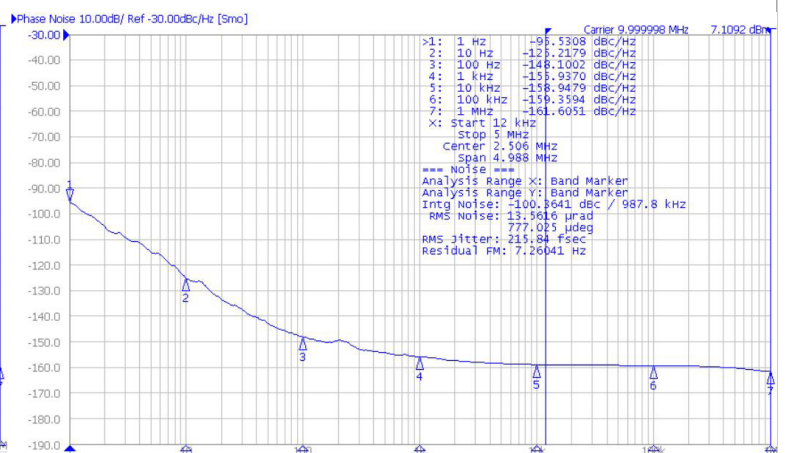
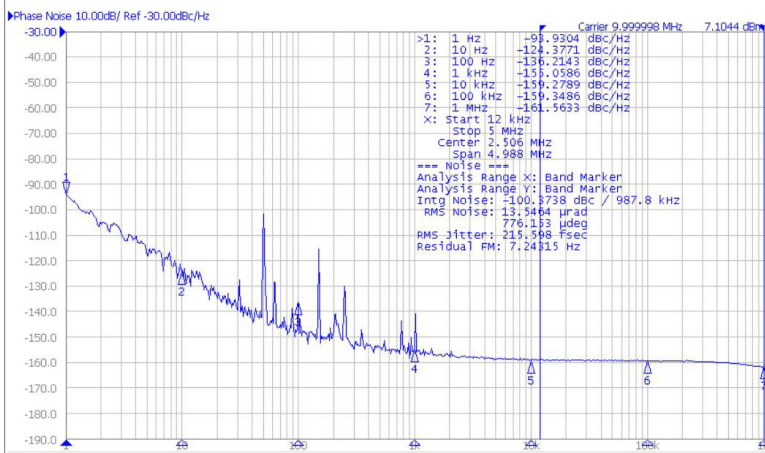

Reflow Profile

Part Marking

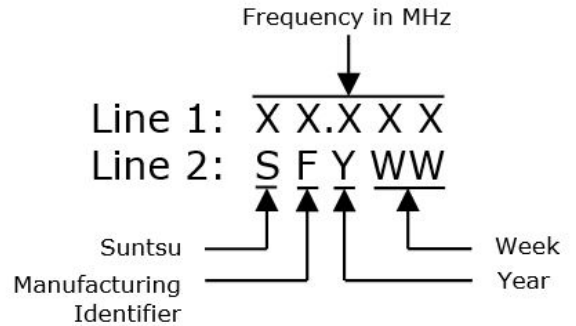
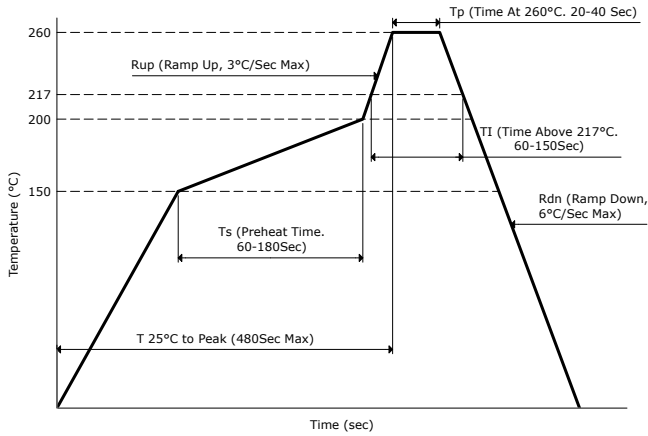

Tape And Reel Dimensions

350pcs/Reel

All dimensions are in millimeters (mm) unless otherwise noted. Drawings are not to scale.

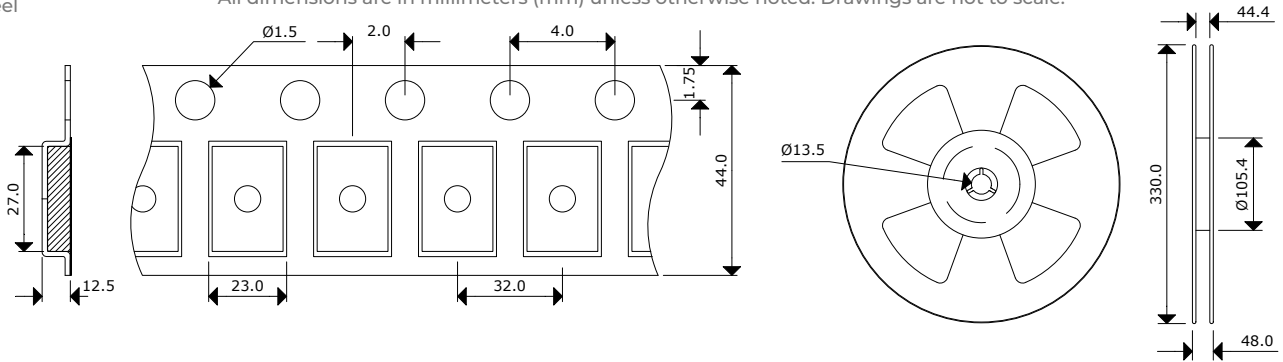

Environmental & Mechanical Specifications

Temperature Cycling	MIL-STD-883, Method 1010, Condition B	Mechanical Shock	50g;11ms; ½sine wave (directions X,Y,Z) IEC68-2-27 Test Ea/Severity 50A
Lead Integrity	MIL-STD-883, Method 2004	Resistance to Soldering	MIL-STD-202, Method 210, Condition A
Solderability	MIL-STD-883, Method 2003	Resistance to Solvents	MIL-STD-202, Method 215
Vibration	Test Condition: 0.75mm ;acceleration:10g;10Hz-500Hz, one cycle per 30 min, test 2hrs. (3 times for each 3 directions X , Y , Z), IEC 68-2-06 Test Fc.		