

未注公差/General tolerances (mm)													0.1/10	
0	>3	>6	>10	>18	>30	>50	>80	>120	>180	>250	>315	>400		>500
~3	~6	~10	~18	~30	~50	~80	~120	~180	~250	~315	~400	~500		
±0.12	±0.18	±0.22	±0.26	±0.31	±0.37	±0.57	±0.80	±0.93	±1.05	±1.15	±1.60	±2.20	±2.50	±2'

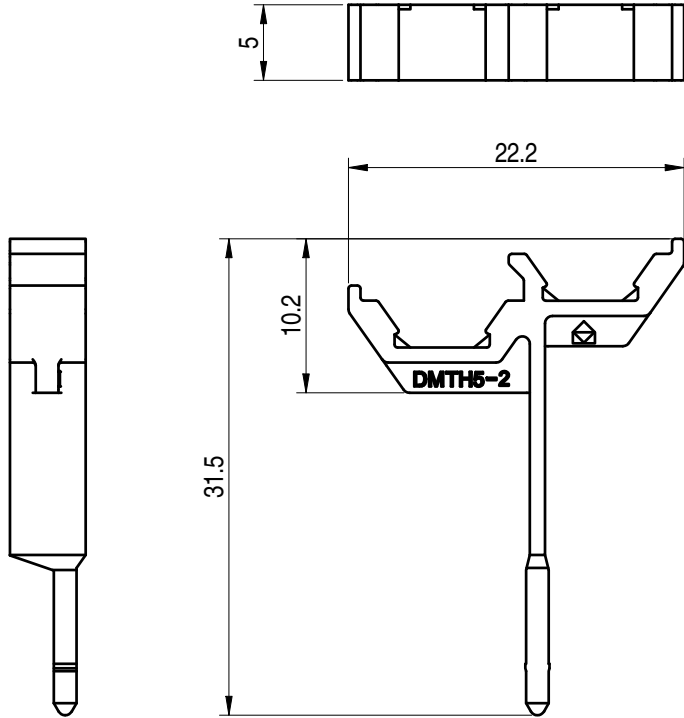

Please refer to the 3D model, for these unmarked dimensions.

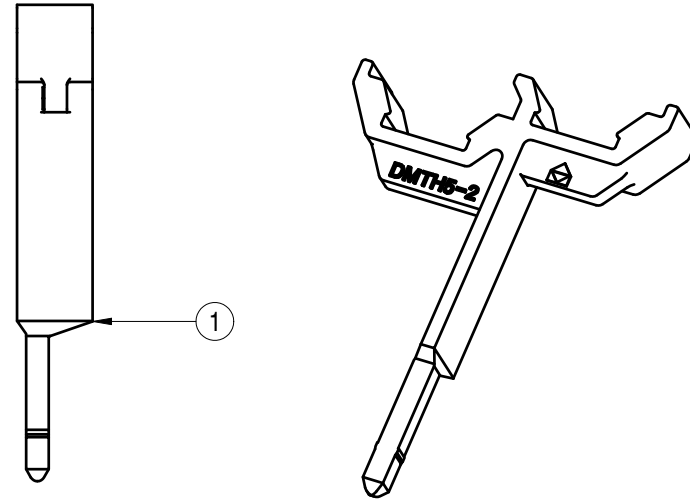

使用温度范围/Operating temperature(°C)		-40~+105	
符合RoHS环保要求/Conform to RoHS		Yes	
ITEM	NAME OF PART	MATERIAL	NOTES
1	Housing	PA66	UL94V-0

		MATERIAL: PA66		SURFACE/COLOR:	
		MAT NO./REV: 11060001530-1 / 00		MAT STATUS: work	
APPD: 李根芳	2022.03.30	NAME			
CHKD: 马恩开	2022.03.30	DMTH5-2-11-00L (H)			
DRFT: 刘承博	2022.03.29	DRAWING NO.	TYPE	DRAWING STATUS	SCALE
		200062132	CUSTOMER DRAWING	已发布	2:1
					SHEET 1/1

00		NEW DRAWING	刘承博	2022.03.29
REV	ECN	DESCRIPTION	DRFT	DATE

Transfer or duplication of this document as well as the utilization or communication of its contents are prohibited unless authorized in writing by Degson. All rights reserved for patent, utility model or design registrations. 除专利权明确标注外, 否则禁止转让、复制、引用、光碟等文件的传播。 未经书面授权, 擅自复制或传播文件内容, 均属于侵权行为, 公司将依法追究法律责任。