

**Features**

- Miniature Footprint
- Low Insertion Loss
- High Attenuation on Harmonic Suppressed
- LTCC Process

**Applications**

- 1520-1610MHz Working Frequency
- Private 5G Network



**Part Numbering Guide**

**S R F B F - 5 H 5 B 3 A - C M B C**



Electrical Parameters	Units	Minimum	Typical	Maximum	Remarks
Frequency	MHz	1520		1610	
Insertion Loss @ 25°C	dB			3.0	
Return Loss	dB	12.0			
Impedance	$\Omega$		50		
Power Capacity	W			3	
Operating Temperature Range	°C	-40		85	
Storage Temperature Range	°C	-40		85	
Attenuation @ DC~960MHz	dB	40			
Attenuation @ 1100~1300MHz	dB	20			
Attenuation @ 1700~1950MHz	dB	30			
Group Delay @ 1559~1563MHz	ns		5.0		
Group Delay @ 1565~1585MHz	ns		5.0		
Group Delay @ 1598~1606MHz	ns		5.0		

**Outline Drawing**

All dimensions are in millimeters (mm) unless otherwise noted. Drawings are not to scale.

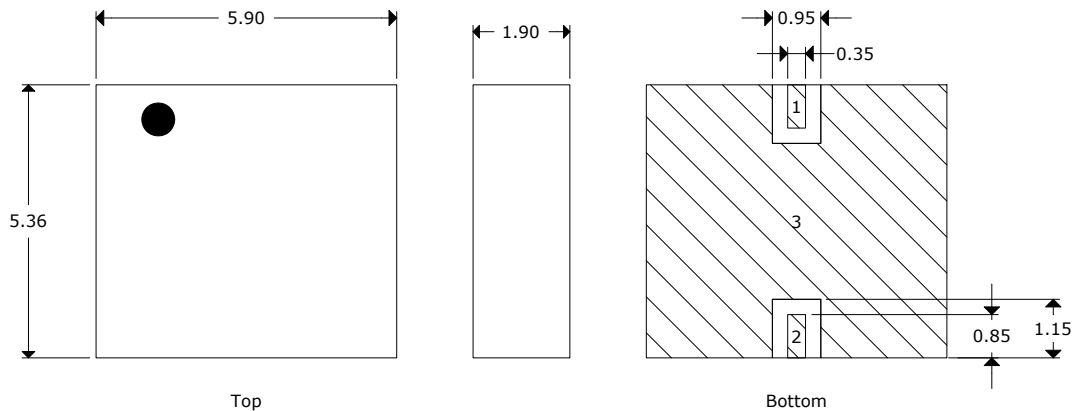

**Typical Electrical Chart**

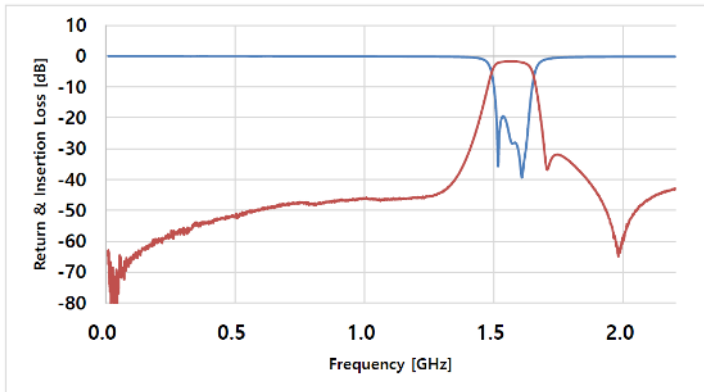

**Land Pattern**

All dimensions are in millimeters (mm) unless otherwise noted.  
 Drawings are not to scale.

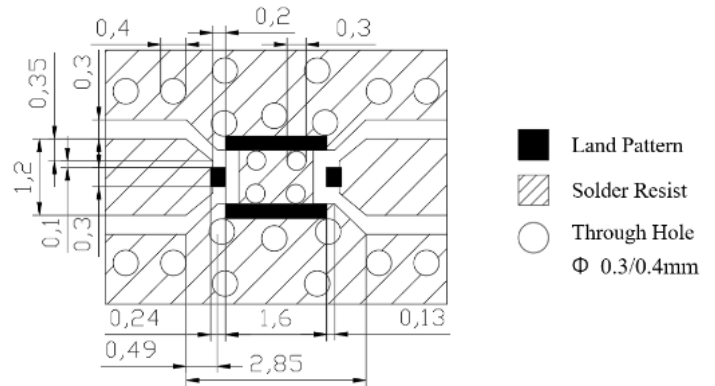

Line width to be designed to match 50Ω characteristic impedance, depending on PCB material and thickness.

**Test Circuit**

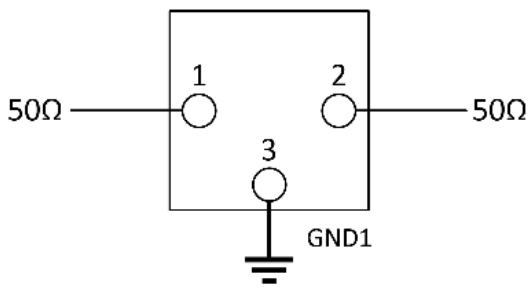

**Reflow Profile**

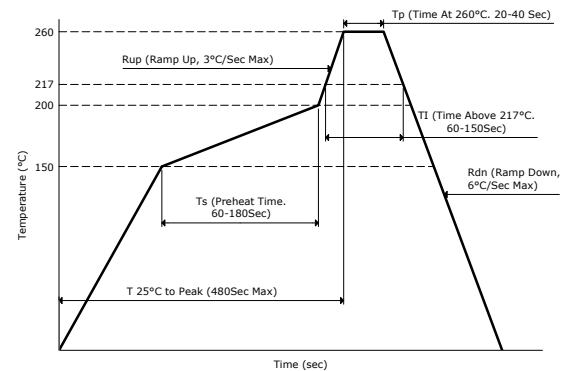

**Tape and Reel Dimensions**

All dimensions are in millimeters (mm) unless otherwise noted.  
 Drawings are not to scale.

3,000 pcs/reel

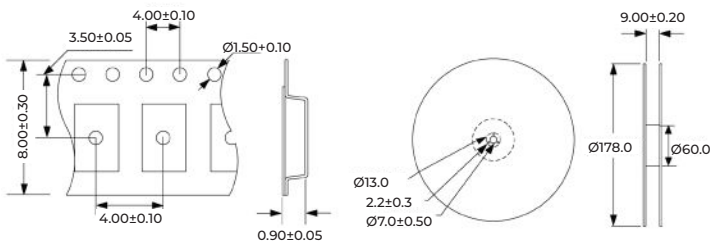

**Markings**

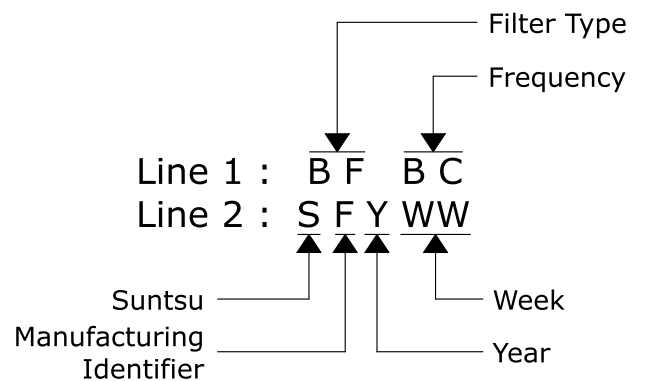

Reliability Test		
Test Item	Test Conditions/Test Method	Specification
Solderability JIS C 0050-4.6 JESD22-B1D	*Solder bath temperature : 235±5°C *Immersion time : 2±0.5 sec Solder : Sn <sup>3</sup> Ag 0.5Cu for lead-free	At least 95% of a surface of each terminal electrode must be covered by fresh solder.
Leaching (Resistance to dissolution of metallization) IEC 60068-2-58	*Solder bath temperature : 260±5°C *Leaching immersion time : 30±0.5 sec Solder : SN63A	Loss of metallization on the edges of each electrode shall not exceed 25%
Resistance to soldering heat JIS C 0050-5.4	*Preheating temperature : 120~150°C, 1 minute *Solder temperature : 270±5°C *Immersion time : 10±1 sec Solder : Sn3Ag 0.5Cu for lead-free Measurement to be made after keeping at room temperature for 24±2 hrs.	No mechanical damage. Electrical specification shall satisfy the descriptions in electrical characteristics under the operational temperature range within -40~85°C. Loss of metallization on the edges of each electrode shall not exceed 25%
Drop Test JIS C 0044	*Height : 75 cm *Test surface : Rigid surface of concrete or steel. *Times : 6 surfaces for each unit; 2 times each side.	No mechanical damage. Electrical specification shall satisfy the description in electrical characteristics under the operational temperature range within -40~85°C.
Vibration JIS C 0040	*Frequency : 10Hz~55Hz~10Hz (1 min) *Total amplitude : 1.5mm *Test times : 6hrs (two hrs each in three mutually perpendicular directions)	No mechanical damage. Electrical specification shall satisfy the descriptions in electrical characteristics under the operational temperature range within -40~85°C.
Adhesive Strength of Termination JIS C 0051-7.4.3	*Pressurizing force : 5N(≤603) ; 10N(>0603) *Test time : 10±1 sec	No remarkable damage or removal of the termination
Bending Test JIS C 0051-7.4.1	The middle part of substrate shall be pressurized by means of the pressurizing rod at a rate of about 1mm/s per second until the deflection becomes 1mm/s and then pressure shall be maintained for 5±1 sec. Measurement to be made after keeping at room temperature for 24±2 hours.	No mechanical damage. Electrical specification shall satisfy the descriptions in electrical characteristics under the operational temperature range within -40~85°C.
Temperature Cycle JIS C 0025	1. 30±3 minutes at -40°C±3°C 2. 10~15 minutes at room temperature 3. 30±3 minutes at 85°C±3°C 4. 10~15 minutes at room temperature Total 100 continuous cycles Measurement to be made after keeping at room temperature for 24±2 hours.	No mechanical damage. Electrical specification shall satisfy the descriptions in electrical characteristics under the operational temperature range within -40~85°C.
High Temperature JIS C 0021	*Temperature : 85°C±2°C *Test duration : 1000+24/-0 hours Measurement to be made after keeping at room temperature for 24±2 hours.	No mechanical damage. Electrical specification shall satisfy the descriptions in electrical characteristics under the operational temperature range within -40~85°C.
Humidity (steady conditions) JIS C 0022	*Humidity : 90% to 95% Relative Humidity *Temperature : 40°C±2°C *Time : 1000+24/-0 hours Measurement to be made after keeping at room temperature for 24±2 hours. **500hrs measuring the first data then 1000hrs data	No mechanical damage. Electrical specification shall satisfy the descriptions in electrical characteristics under the operational temperature range within -40~85°C.
Low Temperature JIS C 0020	*Temperature : -40°C±2°C *Test duration : 1000+24/-0 hours Measurement to be made after keeping at room temperature for 24±2 hours.	No mechanical damage. Electrical specification shall satisfy the descriptions in electrical characteristics under the operational temperature range within -40~85°C.