

Features
• $\pm 20$ ppm (Frequency Stability) Available
• Ceramic Package
• LVPECL
• Low Current Consumption
• Fundamental or 3rd Overtone Crystal Design

Applications
• Fiber Channel
• Gigabit Ethernet
• PCI Express

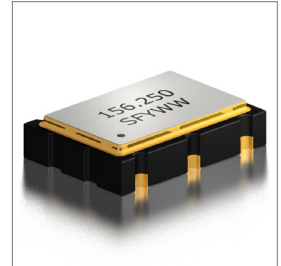

**Part Numbering Guide**

**SLO 75 P 3 A 48 1 - 156.250M**

<p><b>SUNTSU LOW CURRENT OSC</b> 7.0mm x 5.0mm</p> <p><b>LVPECL</b></p> <p><b>SUPPLY VOLTAGE</b> 2: 2.5V<math>\pm</math>5% 3: 3.3V<math>\pm</math>5%</p>	<p><b>FREQUENCY STABILITY</b> A: <math>\pm 50</math>ppm B: <math>\pm 30</math>ppm C: <math>\pm 25</math>ppm *D: <math>\pm 20</math>ppm</p>	<p><b>FREQUENCY</b> MHz</p> <p><b>TRI-STATE (ENABLE/DISABLE)</b> BLANK: No Connection 1: Pin 1</p> <p><b>OPERATING TEMPERATURE RANGE</b> 07: 0°C - +70°C 16: -10°C - +60°C 17: -10°C - +70°C 27: -20°C - +70°C 38: -30°C - +85°C 48: -40°C - +85°C</p>
--	--	--

**RoHS COMPLIANT**

Cage Code : 4GUT4

To customize your parameters, contact a Suntsu representative.

\* For Frequency stability option D, contact a Suntsu representative.

Electrical Parameters	Units	Minimum	Typical	Maximum	Remarks
Frequency Range	MHz	100		320	
Frequency Stability (Includes Initial Tolerance at 25°C, Frequency Stability over Operating Temperature, Output Load Change, Supply Voltage Change, and First Year Aging at 25°C.)	ppm	-20		+20	See part numbering guide for options
Operating Temperature	°C	-40		+85	See part numbering guide for options
Storage Temperature	°C	-55		+125	
Supply Voltage (V <sub>DD</sub> ) - 2.5V Option	V	2.375	2.5	2.625	
Supply Voltage (V <sub>DD</sub> ) - 3.3V Option	V	3.135	3.3	3.465	
Current (I <sub>DD</sub> )	mA			50	
Output Load (LVPECL)	$\Omega$			50	50 $\Omega$ into V <sub>DD</sub> -2.0Vdc
Output Logic Levels High (V <sub>OH</sub> at 2.5V)	V	1.415		1.760	
Output Logic Levels Low (V <sub>OL</sub> at 2.5V)	V	0.670		1.195	
Output Logic Levels High (V <sub>OH</sub> at 3.3V)	V	2.215		2.420	
Output Logic Levels Low (V <sub>OL</sub> at 3.3V)	V	1.470		1.745	
Rise (TR) and Fall (TF) Time	ns		0.15	0.3	Measured at 20% to 80% of Waveform
Symmetry (Duty Cycle)	%	45	50	55	
Tri-State Input Voltage - Enable	V	0.7*V <sub>DD</sub>			No Connection
Tri-State Input Voltage - Disable	V			0.3*V <sub>DD</sub>	
Start-Up Time	ms			5	
Phase Jitter (12kHz ~ 20MHz)	ps		0.12	0.15	

**Outline Drawing & Land Pattern**

All dimensions are in millimeters (mm) unless otherwise noted. Drawings are not to scale.

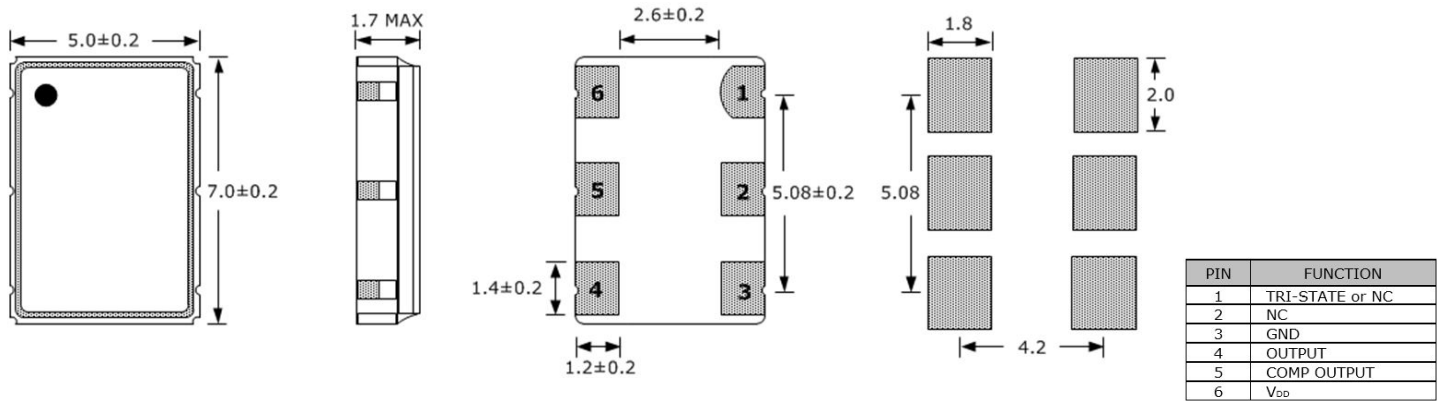

**Test Circuit (LVPECL)**

**Waveform (LVPECL)**

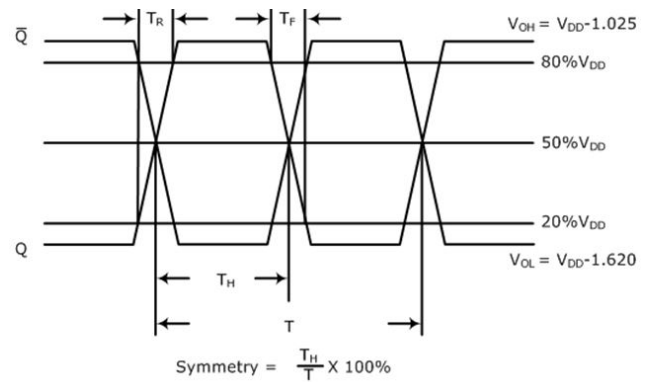
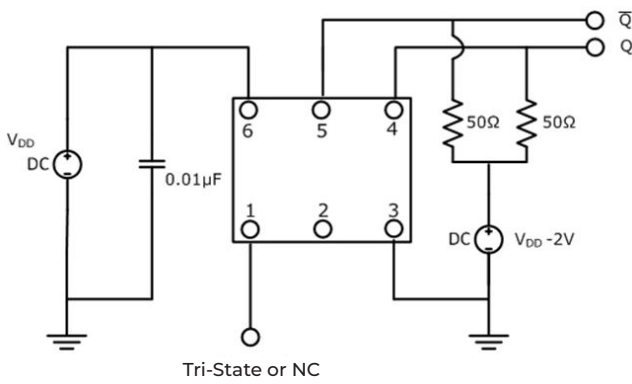

**Typical Phase Noise Performance (Measured By Agilent E5052A)**

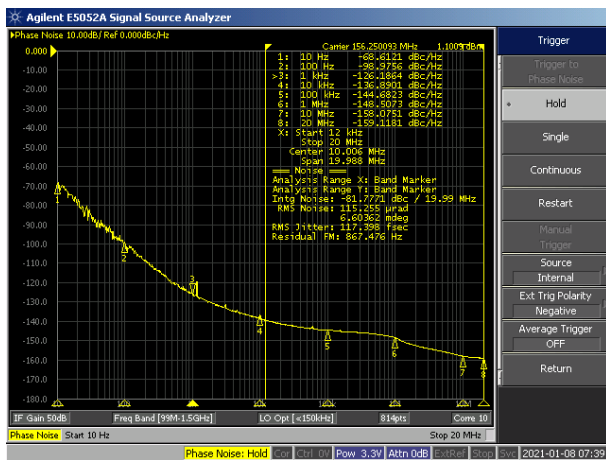

Frequency - 156.250MHz

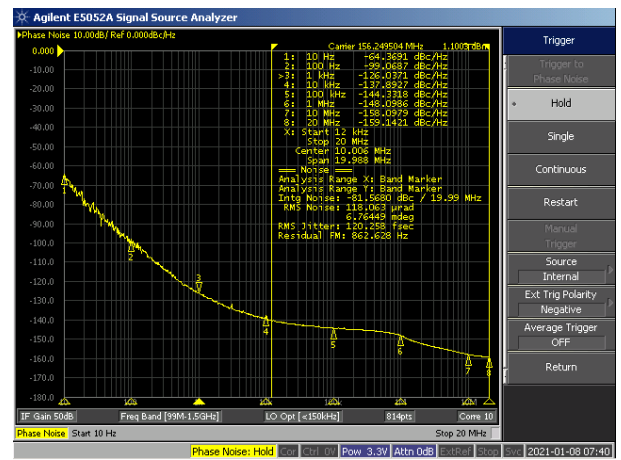

Frequency - 156.250MHz

**Reflow Profile**

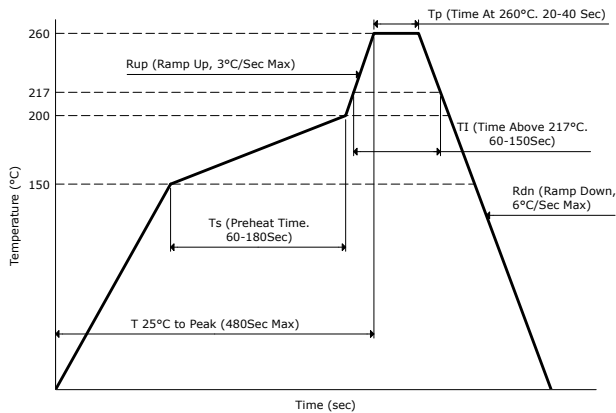

**Part Marking**

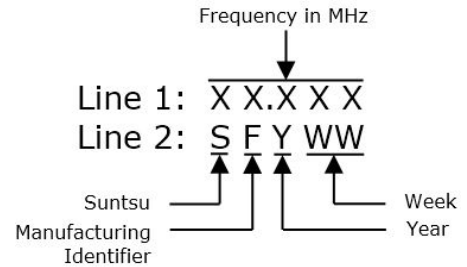

**Tape And Reel Dimensions**

All dimensions are in millimeters (mm) unless otherwise noted. Drawings are not to scale.

1,000pcs/Reel

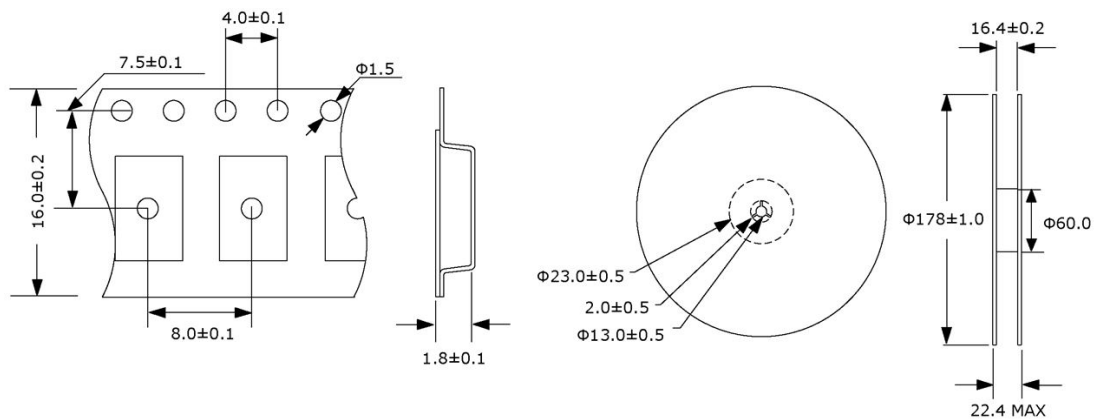

**Environmental Specifications**

**Mechanical Specifications**

Temperature Cycling	MIL-STD-883, Method 1010, Condition B	Mechanical Shock	MIL-STD-202, Method 213, Condition B
Fine Leak Test	MIL-STD-883, Method 1014, Condition A	Vibration	MIL-STD-883, Method 2007, Condition A
Gross Leak Test	MIL-STD-883, Method 1014, Condition C	Moisture Resistance	MIL-STD-883, Method 1004
Solderability	MIL-STD-883, Method 2003	Resistance to Solvents	MIL-STD-202, Method 215
Moisture Sensitivity	J-STD-020, MSL 1	Resistance to Soldering Heat	MIL-STD-202, Method 210, Condition K