

Features
<ul style="list-style-type: none"> ±20ppm (Frequency Stability) Available Wide Frequency Range CMOS Programmed Oscillator Tape and Reel

Applications
<ul style="list-style-type: none"> Micro Processors FPGA Storage Area/Networking Digital Video Portable Computers

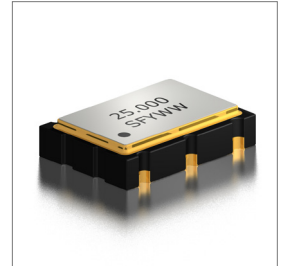

Part Numbering Guide

SQG 75 C 3 A 48 1 N - 25.000M

SUNTSU QUICK TURN OSC
7.0mm x 5.0mm

CMOS

SUPPLY VOLTAGE
2 : 2.5V±5%
3 : 3.3V±5%

FREQUENCY STABILITY
A : ±50ppm
B : ±30ppm
C : ±25ppm
*D : ±20ppm

OPERATING TEMPERATURE RANGE
07 : 0°C - +70°C
16 : -10°C - +60°C
17 : -10°C - +70°C
27 : -20°C - +70°C
38 : -30°C - +85°C
48 : -40°C - +85°C

TRI-STATE (ENABLE/DISABLE)
1 : Pin 1
2 : Pin 2

FREQUENCY MHz

PROGRAMMING MODE
BLANK : Fractional Mode
N : Integer Mode

Cage Code : 4GUT4
To customize your parameters, contact a Suntsu representative.
* For Frequency stability option D, contact a Suntsu representative.

Electrical Parameters	Units	Minimum	Typical	Maximum	Remarks
Frequency Range	MHz	8		250	
Frequency Stability (Includes Initial Tolerance at 25°C, Frequency Stability over Operating Temperature, Output Load Change, Supply Voltage Change, and First Year Aging at 25°C.)	ppm	-20		+20	See part numbering guide for options
Operating Temperature	°C	-40		+85	See part numbering guide for options
Storage Temperature	°C	-55		+125	
Supply Voltage (V _{DD}) - 2.5V option	V	2.375	2.5	2.625	
Supply Voltage (V _{DD}) - 3.3V option	V	3.125	3.3	3.465	
Current (I _{DD}) - 2.5V option	mA			35	
Current (I _{DD}) - 3.3V option	mA			45	
Output Load (CMOS)	pF			15	
Output Logic Levels High (V _{OH})	V	0.9*V _{DD}			
Output Logic Levels Low (V _{OL})	V			0.1*V _{DD}	
Rise (TR) and Fall (TF) Time	ns			3	
Symmetry (Duty Cycle)	%	45	50	55	
Tri-State Input Voltage - Enable	V	0.7*V _{DD}			No Connection
Tri-State Input Voltage - Disable	V			0.3*V _{DD}	
Start-Up Time	ms			10	
Phase Jitter (12kHz ~ 20MHz)	ps			1	Fractional Mode
Phase Jitter (12kHz ~ 20MHz)	ps		0.3	0.5	Integer Mode

Outline Drawing & Land Pattern

All dimensions are in millimeters (mm) unless otherwise noted. Drawings are not to scale.

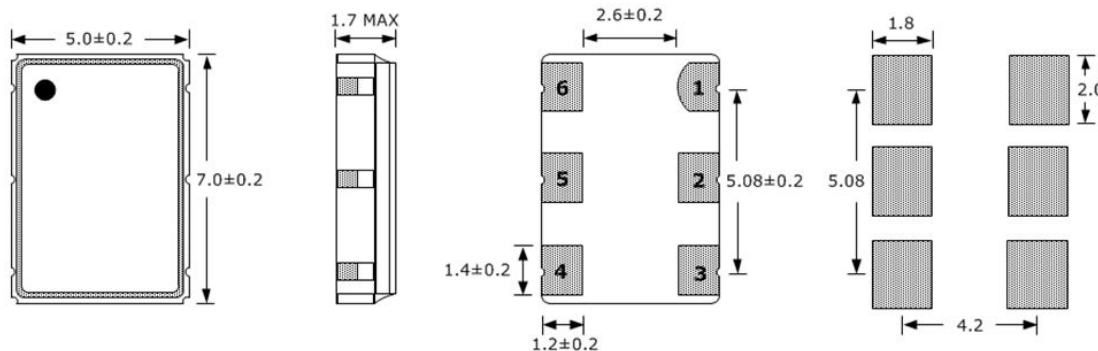

PIN	FUNCTION
1	TRI-STATE or NC
2	TRI-STATE or NC
3	GND
4	OUTPUT
5	NC
6	V _{DD}

Test Circuit (CMOS)

Waveform (CMOS)

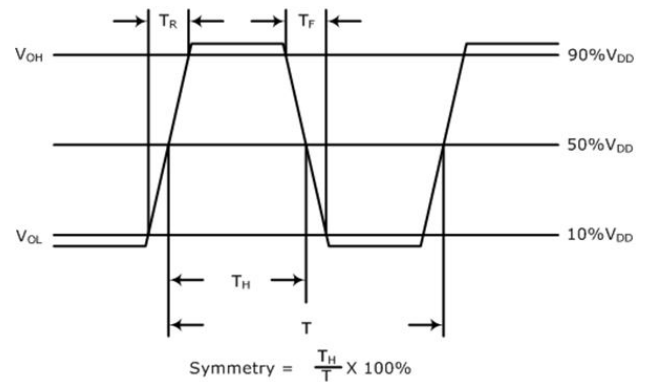
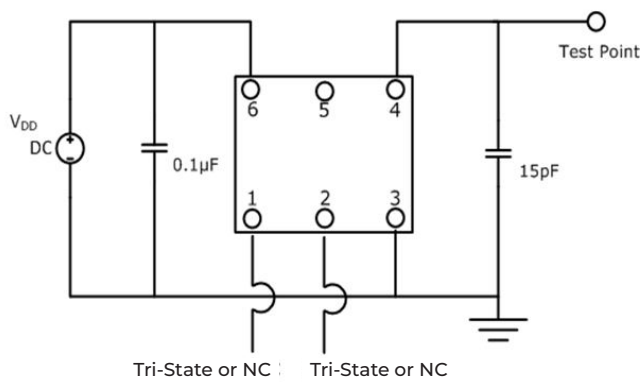

Typical Phase Noise Fractional Performance (Measured By Agilent E5052A)

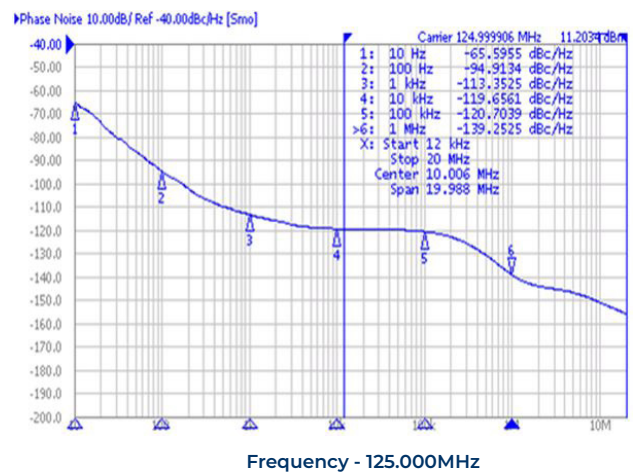
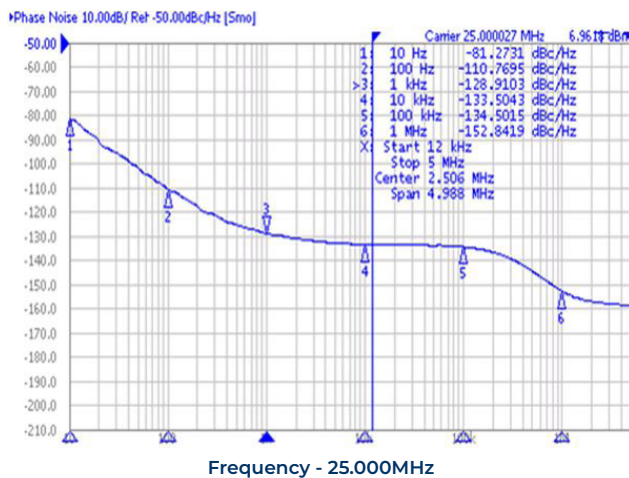

Typical Jitter Fractional Performance (Measured By Agilent E5052A)

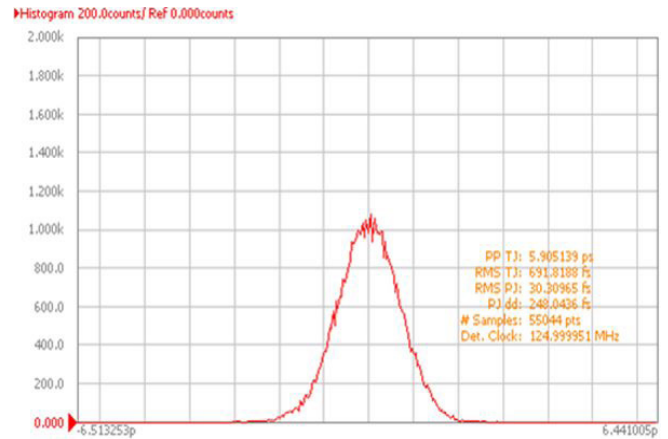
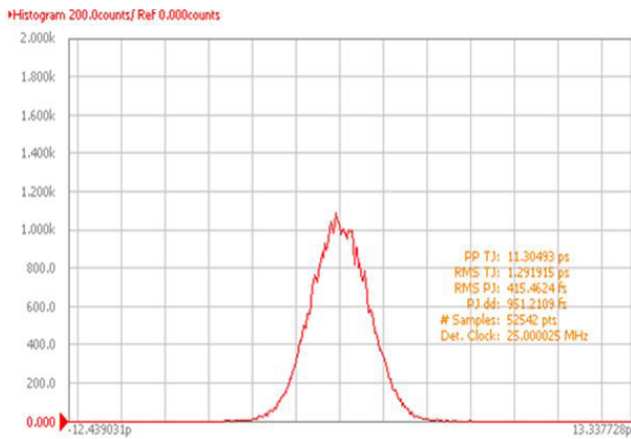

Reflow Profile

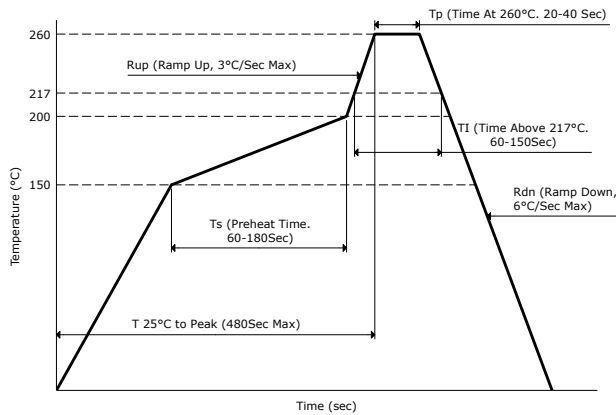

Part Marking

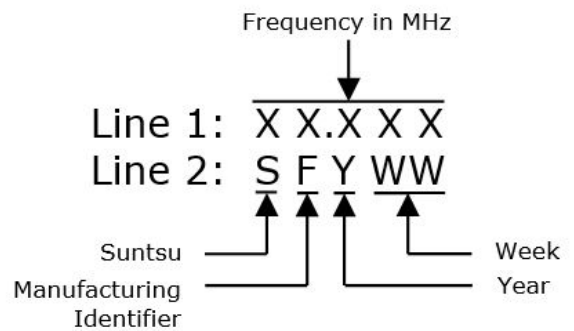

Tape And Reel Dimensions

All dimensions are in millimeters (mm) unless otherwise noted. Drawings are not to scale.

1,000pcs/Reel

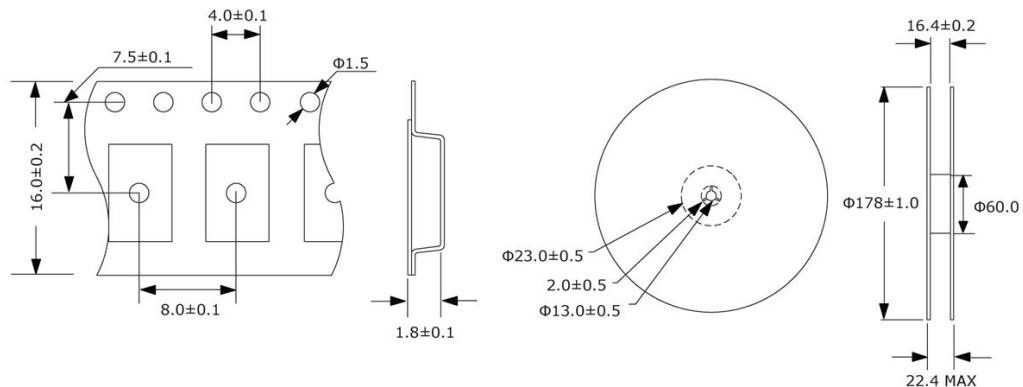

Environmental Specifications		Mechanical Specifications	
Temperature Cycling	MIL-STD-883, Method 1010, Condition B	Mechanical Shock	MIL-STD-202, Method 213, Condition B
Fine Leak Test	MIL-STD-883, Method 1014, Condition A	Vibration	MIL-STD-883, Method 2007, Condition A
Gross Leak Test	MIL-STD-883, Method 1014, Condition C	Moisture Resistance	MIL-STD-883, Method 1004
Solderability	MIL-STD-883, Method 2003	Resistance to Solvents	MIL-STD-202, Method 215
Moisture Sensitivity	J-STD-020, MSL 1	Resistance to Soldering Heat	MIL-STD-202, Method 210, Condition K