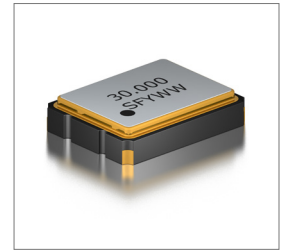

Features
<ul style="list-style-type: none"> ±20ppm (Frequency Stability) Available Ceramic Package LVPECL Programmed VCXO Tape and Reel

Applications
<ul style="list-style-type: none"> Micro Processors FPGA Storage Area/Networking Digital Video Portable Computers

Part Numbering Guide
SQV 32 P 3 A 48 A 2 - 156.250M

 SUNTSU QUICK
 TURN VCXO

3.2mm x 2.5mm

LVPECL

SUPPLY VOLTAGE
 2 : 2.5V±5%
 3 : 3.3V±5%

FREQUENCY STABILITY
 A : ±50ppm
 B : ±30ppm
 C : ±25ppm
 D : ±20ppm
 *E : ±15ppm

OPERATING TEMPERATURE RANGE
 07 : 0°C - +70°C
 16 : -10°C - +60°C
 17 : -10°C - +70°C
 27 : -20°C - +70°C
 38 : -30°C - +85°C
 48 : -40°C - +85°C

PULLABILITY
 A : ±150ppm
 B : ±100ppm
 C : ±80ppm

FREQUENCY
 MHz

TRI-STATE (ENABLE/DISABLE)
 2 : Pin 2

Cage Code: 4GUT4

To customize your parameters contact a Suntsu representative.

* For frequency stability option E contact a Suntsu representative.

Electrical Parameters	Units	Minimum	Typical	Maximum	Remarks
Frequency Range	MHz	8		1500	
Frequency Stability (Includes Initial Tolerance at 25°C, Frequency Stability over Operating Temperature, Output Load Change, Supply Voltage Change, and First Year Aging at 25°C.)	ppm	-20		20	See part numbering guide for options.
Operating Temperature	°C	-40		85	See part numbering guide for options.
Storage Temperature	°C	-55		125	
Supply Voltage (V _{DD}) 2.5V Option	V	2.375	2.5	2.625	
Supply Voltage (V _{DD}) 3.3V Option	V	3.135	3.3	3.465	See part numbering guide for options.
Current (I _{DD}) 2.5V Option	mA			65	
Current (I _{DD}) 3.3V Option	mA			70	
Current Voltage (V _C) 2.5V Option	V	0		2.5	
Current Voltage (V _C) 3.3V Option	V	0		3.3	
Pullability	ppm	±50	±100	±150	See part numbering guide for options.
Linearity	%			10	
Output Load (LVPECL)	Ω			50	50 Ω into V _{DD} -2.0V _{DC}
Output Logic HIGH Level (V _{OH})	V	V _{DD} -1.025			
Output Logic LOW Level (V _{OL})	V			V _{DD} -1.620	
Rise (T _R) And Fall (T _F) Time	ns			1	
Symmetry (Duty Cycle)	%	45	50	55	
Tri-State Input Voltage - Enable	V	0.7*V _{DD}			No Connection
Tri-State Input Voltage - Disable	V			0.3*V _{DD}	
Start-Up Time	ms			10	
Phase Jitter (12KHz ~ 20MHz)	ps		0.7	1.5	

Outline Drawing & Land Pattern

All dimensions are in millimeters (mm) unless otherwise noted. Drawings are not to scale.

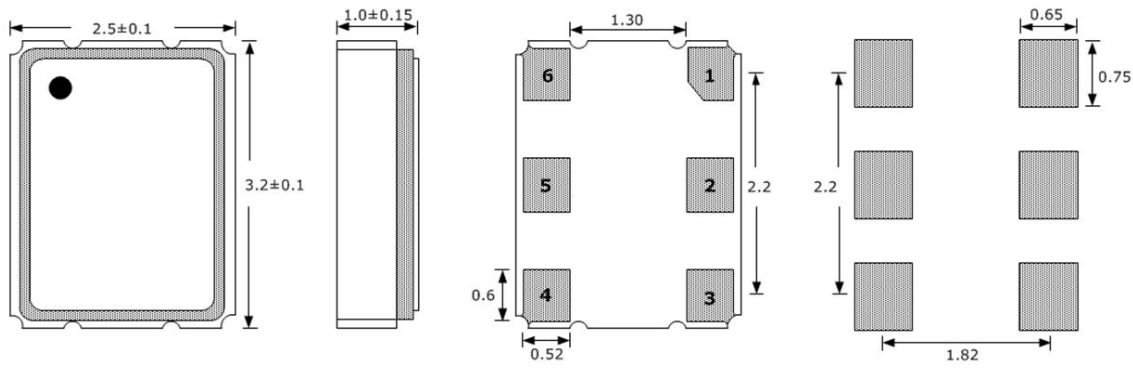

PIN	FUNCTION
1	Voltage Control
2	E/D
3	GND
4	OUTPUT
5	COMP OUTPUT
6	VDD

Test Circuit (LVPECL)

Waveform (LVPECL)

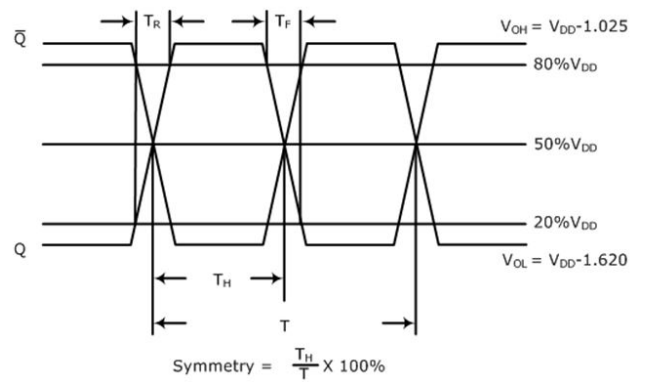
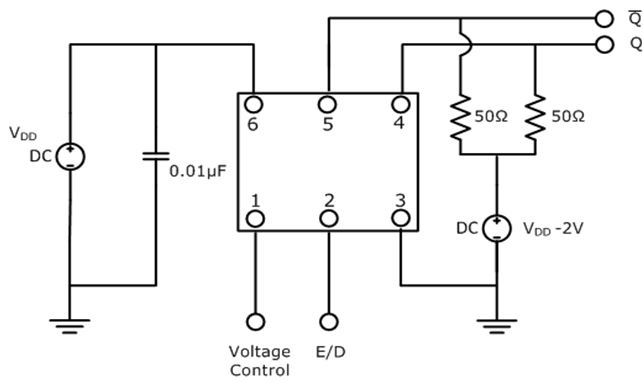

Typical Phase Noise Performance (Measured By Agilent E5052A)

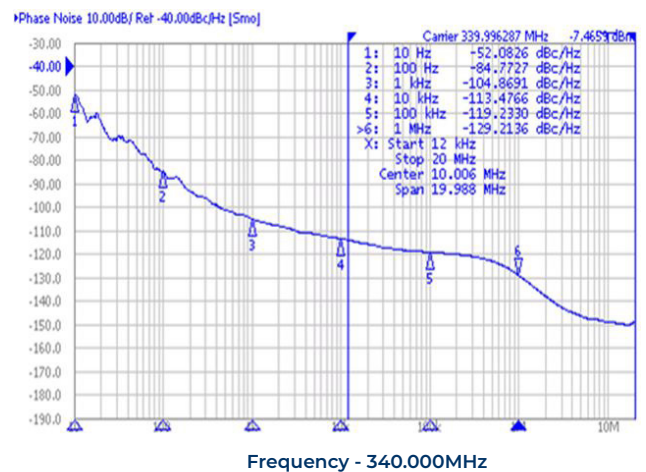
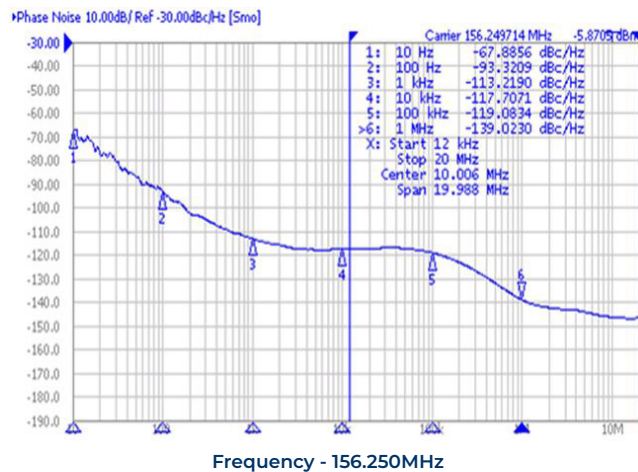

Typical Jitter Performance (Measured By Agilent E5052A)

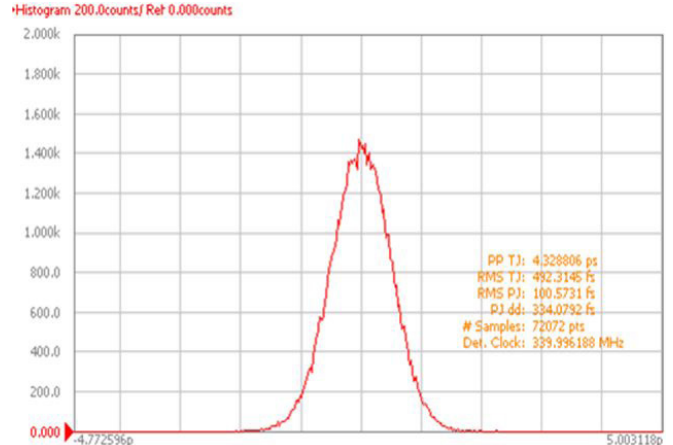
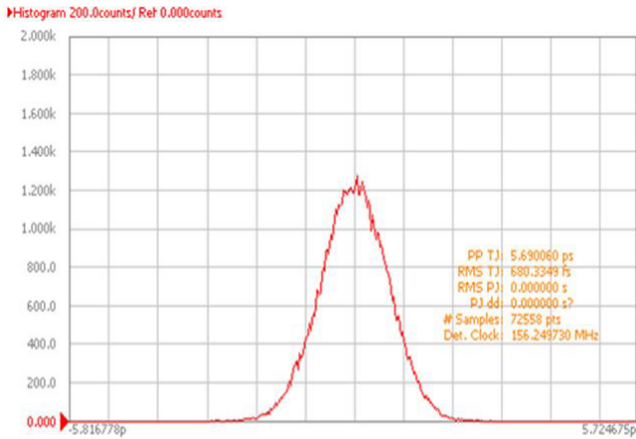

Reflow Profile

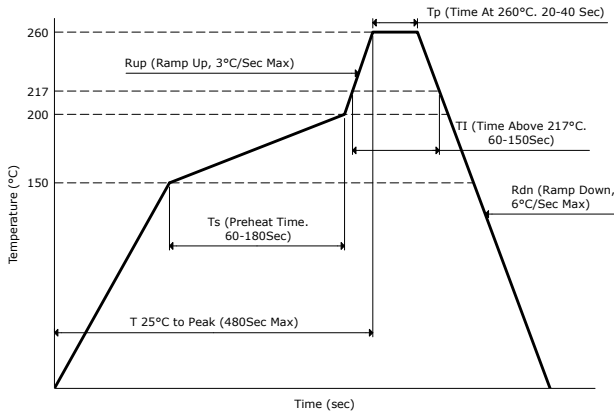

Part Marking

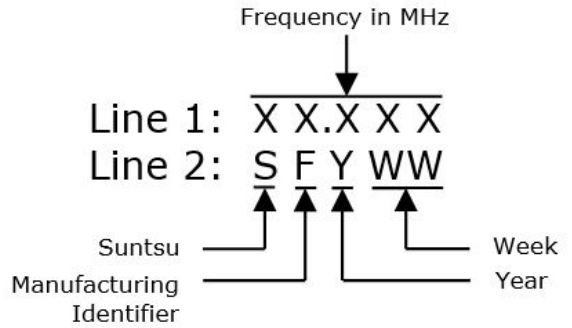

Tape And Reel Dimensions

All dimensions are in millimeters (mm) unless otherwise noted. Drawings are not to scale.

1,000pcs/Reel

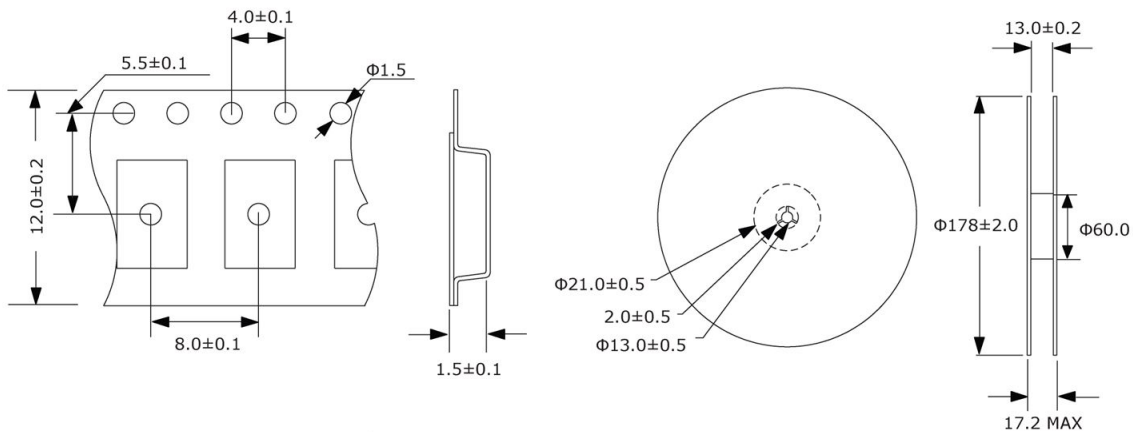

Environmental Specifications		Mechanical Specifications	
Temperature Cycling	MIL-STD-883, Method 1010, Condition B	Mechanical Shock	MIL-STD-202, Method 213, Condition B
Fine Leak Test	MIL-STD-883, Method 1014, Condition A	Vibration	MIL-STD-883, Method 2007, Condition A
Gross Leak Test	MIL-STD-883, Method 1014, Condition C	Moisture Resistance	MIL-STD-883, Method 1004
Solderability	MIL-STD-883, Method 2003	Resistance to Solvents	MIL-STD-202, Method 215
Moisture Sensitivity	J-STD-020, MSL 1	Resistance to Soldering Heat	MIL-STD-202, Method 210, Condition K