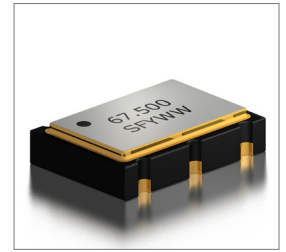
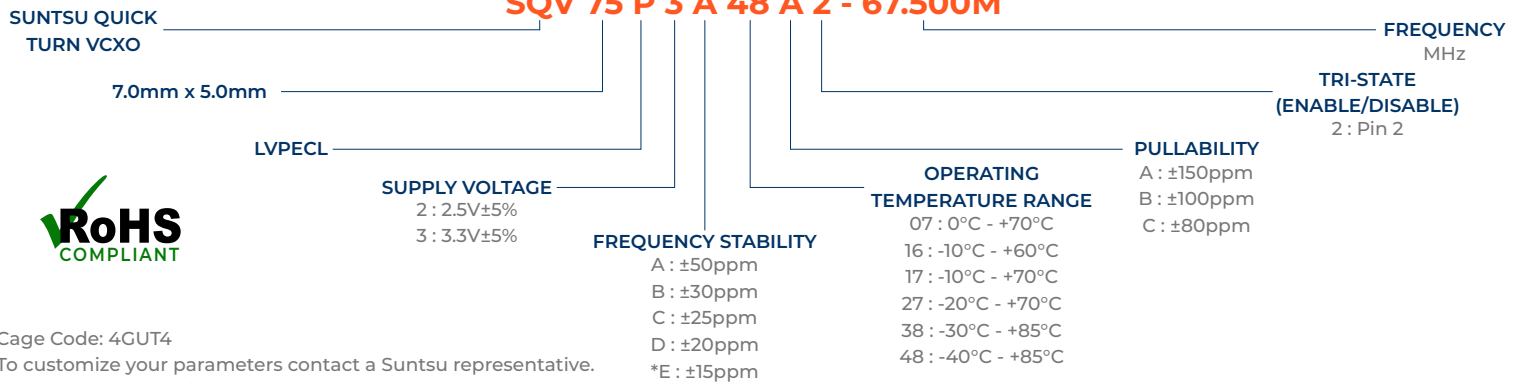

Features
• $\pm 20$ ppm (Frequency Stability) Available
• Ceramic Package
• LVPECL
• Programmed VCXO
• Tape and Reel

Applications
• Micro Processors
• FPGA
• Storage Area/Networking
• Digital Video
• Portable Computers

**Part Numbering Guide**
**SQV 75 P 3 A 48 A 2 - 67.500M**

Cage Code: 4GUT4

To customize your parameters contact a Suntsu representative.

\* For frequency stability option E contact a Suntsu representative.

Electrical Parameters	Units	Minimum	Typical	Maximum	Remarks
Frequency Range	MHz	8		1500	
Frequency Stability (Includes Initial Tolerance at 25°C, Frequency Stability over Operating Temperature, Output Load Change, Supply Voltage Change, and First Year Aging at 25°C.)	ppm	-20		20	See part numbering guide for options.
Operating Temperature	°C	-40		85	See part numbering guide for options.
Storage Temperature	°C	-55		125	
Supply Voltage (V <sub>DD</sub> ) 2.5V Option	V	2.375	2.5	2.625	
Supply Voltage (V <sub>DD</sub> ) 3.3V Option	V	3.135	3.3	3.465	
Current (I <sub>DD</sub> ) 2.5V Option	mA			65	
Current (I <sub>DD</sub> ) 3.3V Option	mA			70	
Current Voltage (V <sub>C</sub> ) 2.5V Option	V	0		2.5	
Current Voltage (V <sub>C</sub> ) 3.3V Option	V	0		3.3	
Pullability	ppm	±50	±100	±150	See part numbering guide for options.
Linearity	%			10	
Output Load (LVPECL)	Ω			50	50 Ω into V <sub>DD</sub> -2.0V <sub>DC</sub>
Output Logic HIGH Level (V <sub>OH</sub> )	V	V <sub>DD</sub> -1.025			
Output Logic LOW Level (V <sub>OL</sub> )	V			V <sub>DD</sub> -1.620	
Rise (T <sub>R</sub> ) And Fall (T <sub>F</sub> ) Time	ns			1	
Symmetry (Duty Cycle)	%	45	50	55	
Tri-State Input Voltage - Enable	V	0.7*V <sub>DD</sub>			No Connection
Tri-State Input Voltage - Disable	V			0.3*V <sub>DD</sub>	
Start-Up Time	ms			10	
Phase Jitter (12KHz ~ 20MHz)	ps		0.7	1.5	

**Outline Drawing & Land Pattern**

All dimensions are in millimeters (mm) unless otherwise noted. Drawings are not to scale.

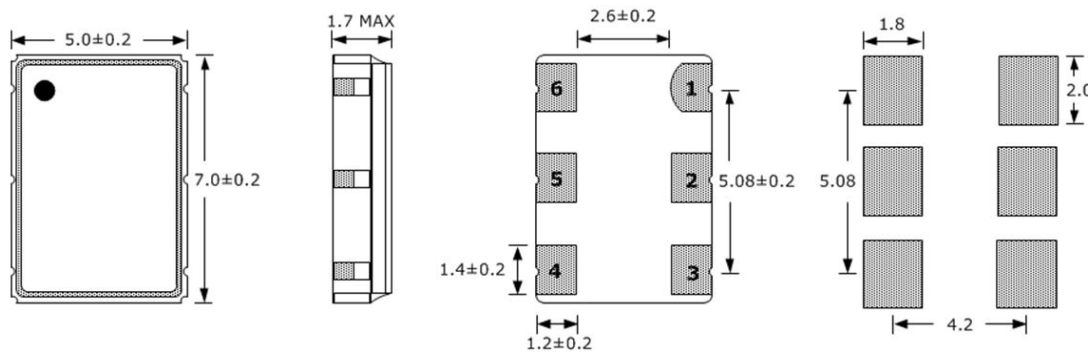

PIN	FUNCTION
1	Voltage Control
2	E/D
3	GND
4	OUTPUT
5	COMP OUTPUT
6	VDD

**Test Circuit (LVPECL)**

**Waveform (LVPECL)**

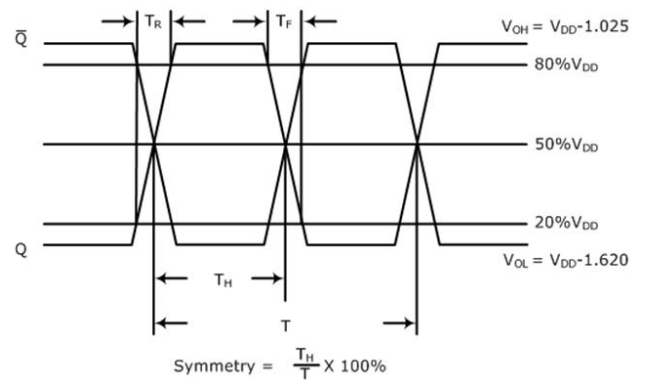
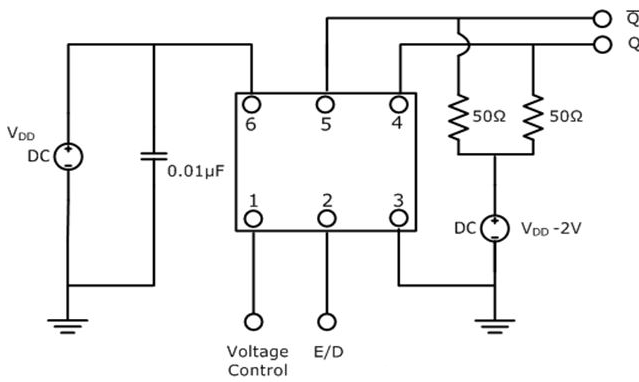

**Typical Phase Noise Performance (Measured By Agilent E5052A)**

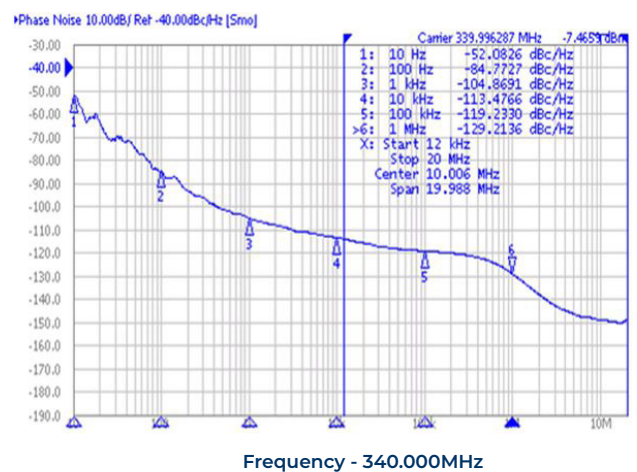
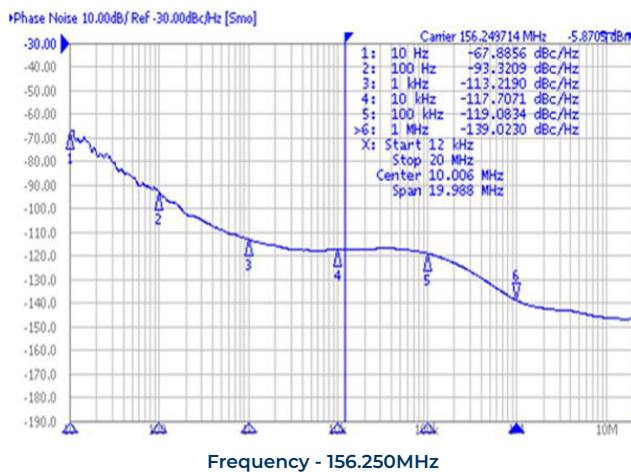

### Typical Jitter Performance (Measured By Agilent E5052A)

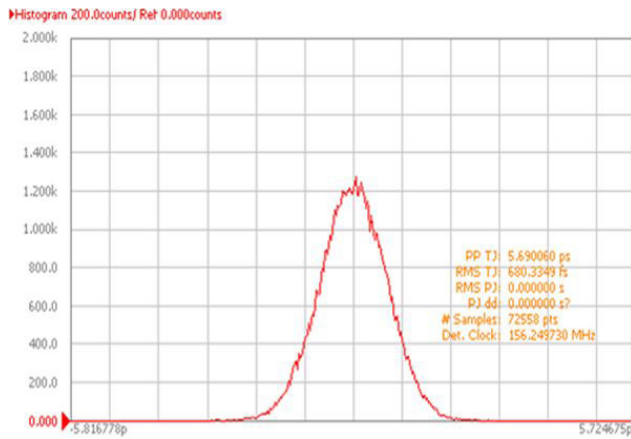

Frequency - 156.250MHz

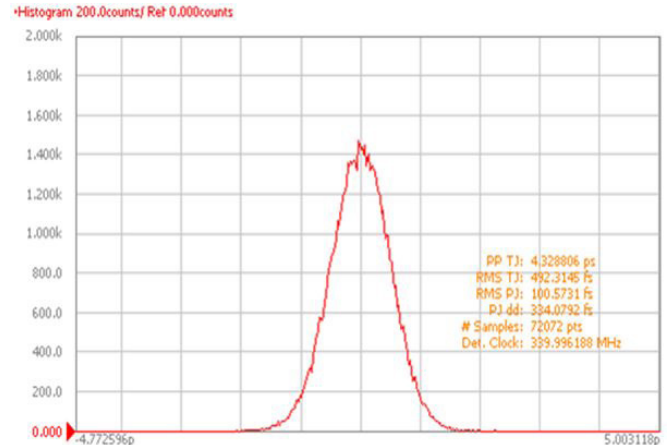

Frequency - 340.000MHz

### Reflow Profile

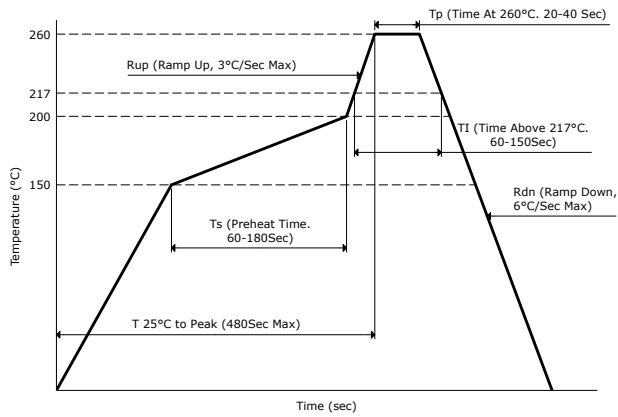

### Part Marking

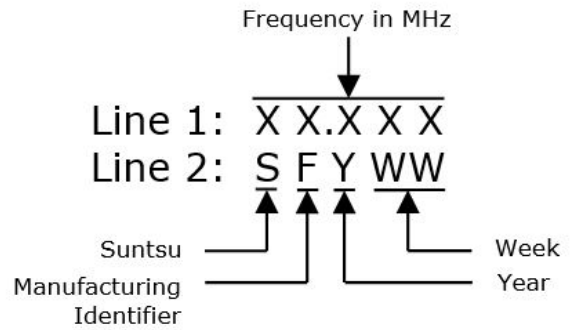

### Tape And Reel Dimensions

All dimensions are in millimeters (mm) unless otherwise noted. Drawings are not to scale.

1,000pcs/Reel

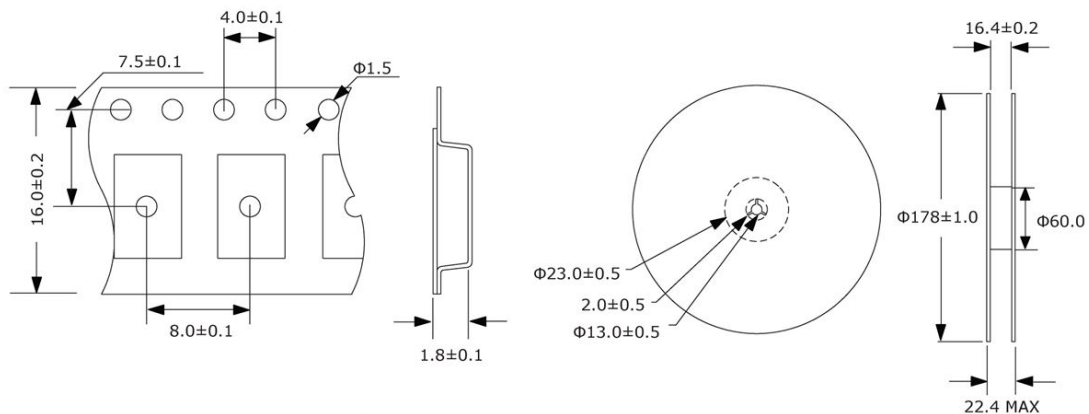

Environmental Specifications		Mechanical Specifications	
Temperature Cycling	MIL-STD-883, Method 1010, Condition B	Mechanical Shock	MIL-STD-202, Method 213, Condition B
Fine Leak Test	MIL-STD-883, Method 1014, Condition A	Vibration	MIL-STD-883, Method 2007, Condition A
Gross Leak Test	MIL-STD-883, Method 1014, Condition C	Moisture Resistance	MIL-STD-883, Method 1004
Solderability	MIL-STD-883, Method 2003	Resistance to Solvents	MIL-STD-202, Method 215
Moisture Sensitivity	J-STD-020, MSL 1	Resistance to Soldering Heat	MIL-STD-202, Method 210, Condition K