

Features
• ± 20 ppm (Frequency Stability) Available
• Ceramic Package
• LVDS
• Ultra Low Phase Jitter (67fs Typical)
• Tape and Reel
• Fundamental or 3rd Overtone Crystal Design

Applications
• Fiber Channel
• Gigabit Ethernet
• PCI Express

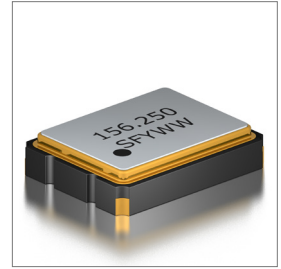

Part Numbering Guide

SUO 32 L 3 A 48 1 - 156.250M

SUNTSU ULTRA LOW JITTER OSC
3.2mm x 2.5mm

LVDS

SUPPLY VOLTAGE
 1 : 1.8V \pm 5%
 2 : 2.5V \pm 5%
 3 : 3.3V \pm 5%

FREQUENCY STABILITY
 A : ± 50 ppm
 B : ± 30 ppm
 C : ± 25 ppm
 *D : ± 20 ppm

OPERATING TEMPERATURE RANGE
 07 : 0°C - +70°C
 16 : -10°C - +60°C
 17 : -10°C - +70°C
 27 : -20°C - +70°C
 38 : -30°C - +85°C
 48 : -40°C - +85°C

FREQUENCY MHz
TRI-STATE (ENABLE/DISABLE)
 BLANK : No Connection
 1 : Pin 1

Cage Code : 4GUT4
 To customize your parameters, contact a Suntsu representative.
 * For Frequency stability option D, contact a Suntsu representative.

Electrical Parameters	Units	Minimum	Typical	Maximum	Remarks
Frequency Range	MHz	100		320	135~175MHz(1.8V), 100~320MHz(2.5&3.3V)
Frequency Stability (Includes Initial Tolerance at 25°C, Frequency Stability over Operating Temperature, Output Load Change, Supply Voltage Change, and First Year Aging at 25°C.)	ppm	-20		+20	See part numbering guide for options
Operating Temperature	°C	-40		+85	See part numbering guide for options
Storage Temperature	°C	-55		+125	
Supply Voltage (V _{DD}) - 1.8V Option	V	1.710	1.8	1.890	
Supply Voltage (V _{DD}) - 2.5V Option	V	2.375	2.5	2.625	
Supply Voltage (V _{DD}) - 3.3V Option	V	3.135	3.3	3.465	
Current (I _{DD})	mA			35	
Output Load (LVDS)	Ω			100	
Output Logic Levels High (V _{OH})	V		1.43	1.6	
Output Logic Levels Low (V _{OL})	V	0.9	1.1		
Differential Output Voltage (V _{OD})	mV	247	350	454	
Differential Output Error (pV _{OD})	mV			50	
Offset Voltage (V _{OS})	V	1.125	1.250	1.375	
Offset Error (pV _{OS})	mV			50	
Rise (TR) and Fall (TF) Time	ns		0.25	0.5	
Symmetry (Duty Cycle)	%	45	50	55	
Tri-State Input Voltage - Enable	V	0.7*V _{DD}			No Connection
Tri-State Input Voltage - Disable	V			0.3*V _{DD}	
Start-Up Time	ms			5.0	
Phase Jitter (12kHz ~ 20MHz)	ps		0.067	0.1	

Outline Drawing & Land Pattern

All dimensions are in millimeters (mm) unless otherwise noted. Drawings are not to scale.

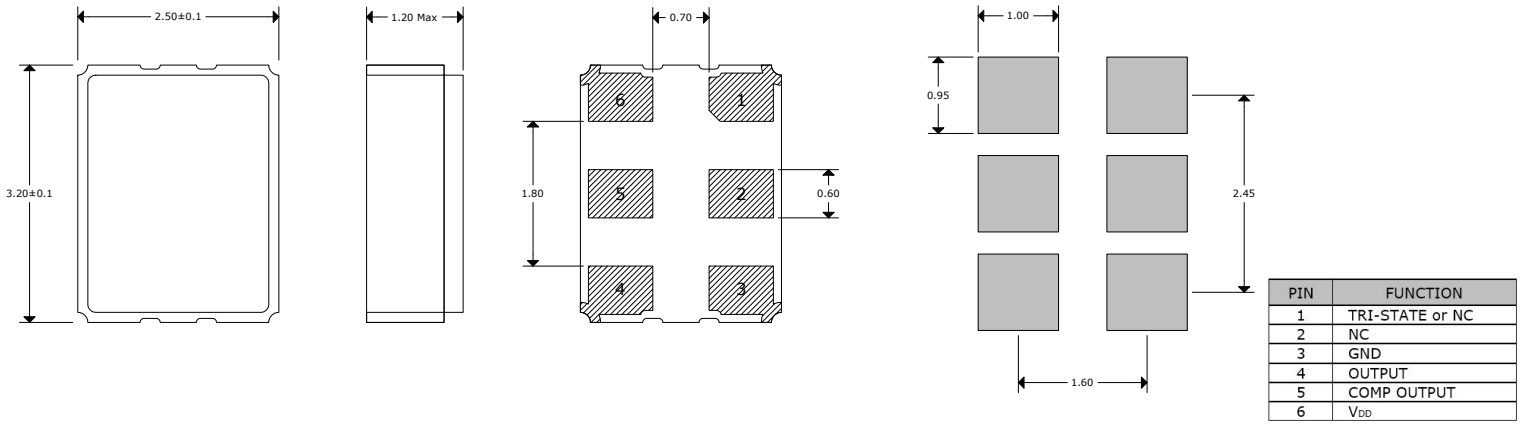

Test Circuit (LVDS)

Waveform (LVDS)

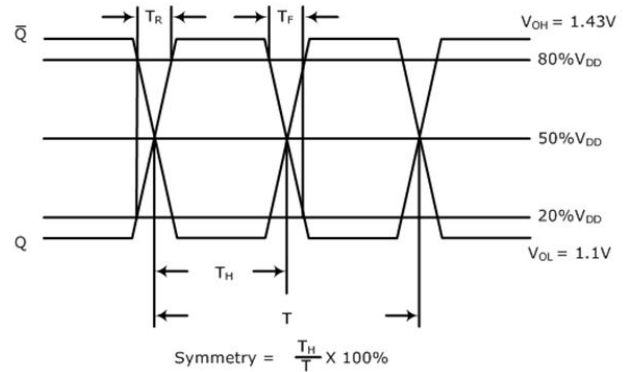
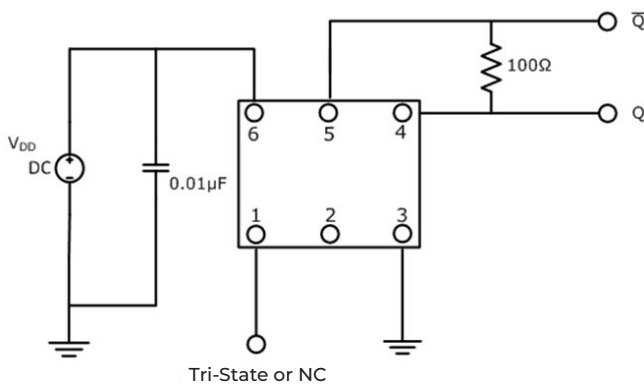

Typical Phase Noise Performance (Measured By Agilent E5052A)

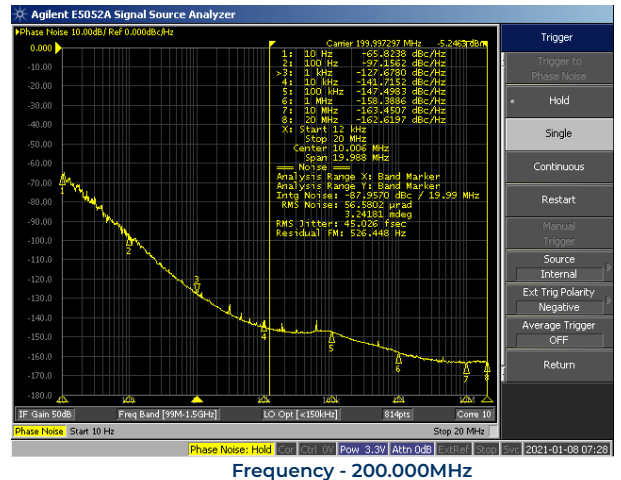
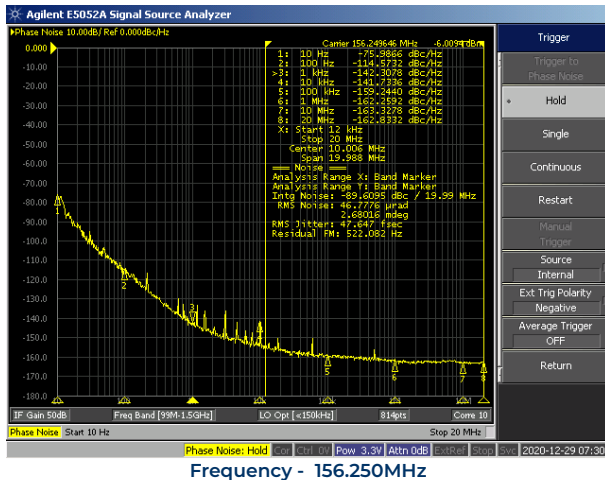

Reflow Profile

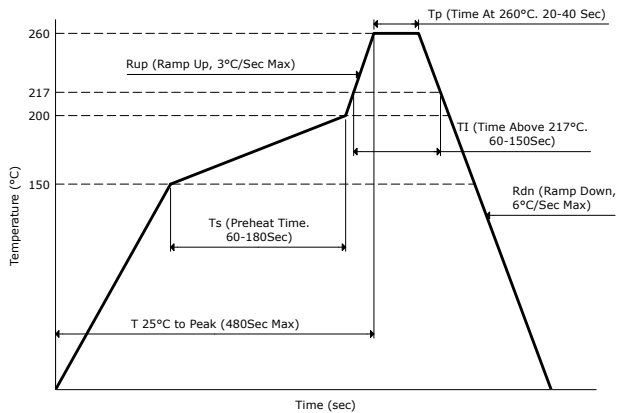

Part Marking

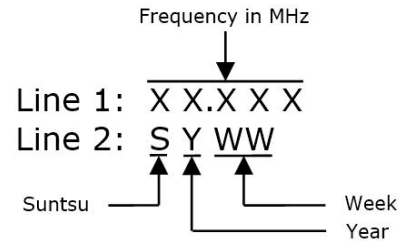

Tape And Reel Dimensions

All dimensions are in millimeters (mm) unless otherwise noted. Drawings are not to scale.

3,000pcs/Reel

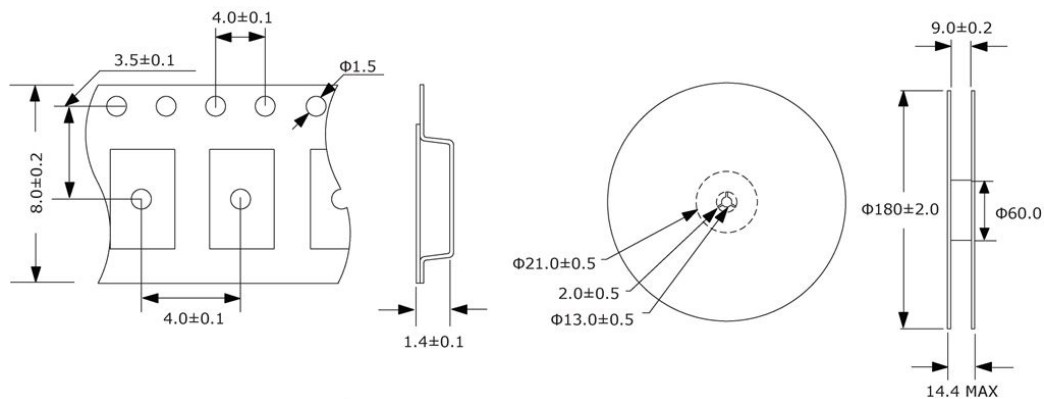

Environmental Specifications

Temperature Cycling	MIL-STD-883, Method 1010, Condition B
Fine Leak Test	MIL-STD-883, Method 1014, Condition A
Gross Leak Test	MIL-STD-883, Method 1014, Condition C
Solderability	MIL-STD-883, Method 2003
Moisture Sensitivity	J-STD-020, MSL 1

Mechanical Specifications

Mechanical Shock	MIL-STD-202, Method 213, Condition B
Vibration	MIL-STD-883, Method 2007, Condition A
Moisture Resistance	MIL-STD-883, Method 1004
Resistance to Solvents	MIL-STD-202, Method 215
Resistance to Soldering Heat	MIL-STD-202, Method 210, Condition K