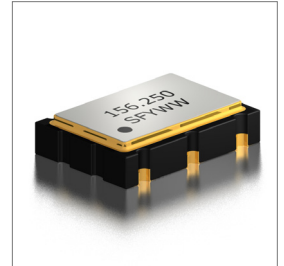

Features
• $\pm 20$ ppm (Frequency Stability) Available
• Ceramic Package
• LVDS
• Ultra Low Phase Jitter (67fs Typical)
• Tape and Reel
• Fundamental or 3rd Overtone Crystal Design

Applications
• Fiber Channel
• Gigabit Ethernet
• PCI Express

**Part Numbering Guide**
**SUO 75 L 3 A 48 1 - 156.250M**

 SUNTSU ULTRA  
 LOW JITTER OSC

7.0mm x 5.0mm

LVDS

SUPPLY VOLTAGE

- 1 : 1.8V $\pm$ 5%
- 2 : 2.5V $\pm$ 5%
- 3 : 3.3V $\pm$ 5%

FREQUENCY STABILITY

- A :  $\pm 50$ ppm
- B :  $\pm 30$ ppm
- C :  $\pm 25$ ppm
- \*D :  $\pm 20$ ppm

OPERATING TEMPERATURE

RANGE

- 07 : 0°C - +70°C
- 16 : -10°C - +60°C
- 17 : -10°C - +70°C
- 27 : -20°C - +70°C
- 38 : -30°C - +85°C
- 48 : -40°C - +85°C

 FREQUENCY  
 MHz

 TRI-STATE  
 (ENABLE/DISABLE)  
 BLANK : No Connection  
 1 : Pin 1

Cage Code : 4GUT4

To customize your parameters, contact a Suntsu representative.

\* For Frequency stability option D, contact a Suntsu representative.

Electrical Parameters	Units	Minimum	Typical	Maximum	Remarks
Frequency Range*	MHz	100		320	135~175MHz(1.8V), 100~320MHz(2.5&3.3V)
Frequency Stability (Includes Initial Tolerance at 25°C, Frequency Stability over Operating Temperature, Output Load Change, Supply Voltage Change, and First Year Aging at 25°C.)	ppm	-20		+20	See part numbering guide for options
Operating Temperature	°C	-40		+85	See part numbering guide for options
Storage Temperature	°C	-55		+125	
Supply Voltage (V <sub>DD</sub> ) - 1.8V Option	V	1.710	1.8	1.890	
Supply Voltage (V <sub>DD</sub> ) - 2.5V Option	V	2.375	2.5	2.625	
Supply Voltage (V <sub>DD</sub> ) - 3.3V Option	V	3.135	3.3	3.465	
Current (I <sub>DD</sub> )*	mA			35	
Output Load (LVDS)	$\Omega$			100	
Output Logic Levels High (V <sub>OH</sub> )	V		1.43	1.6	
Output Logic Levels Low (V <sub>OL</sub> )	V	0.9	1.1		
Differential Output Voltage (V <sub>OD</sub> )	mV	247	350	454	
Differential Output Error ( $\Delta$ V <sub>OD</sub> )	mV			50	
Offset Voltage (V <sub>OS</sub> )	V	1.125	1.250	1.375	
Offset Error ( $\Delta$ V <sub>OS</sub> )	mV			50	
Rise (TR) and Fall (TF) Time	ns		0.25	0.5	
Symmetry (Duty Cycle)	%	45	50	55	
Tri-State Input Voltage - Enable	V	0.7*V <sub>DD</sub>			No Connection
Tri-State Input Voltage - Disable	V			0.3*V <sub>DD</sub>	
Start-Up Time	ms			5.0	
Phase Jitter (12kHz ~ 20MHz)	ps		0.067	0.1	

**Outline Drawing & Land Pattern**

All dimensions are in millimeters (mm) unless otherwise noted. Drawings are not to scale.

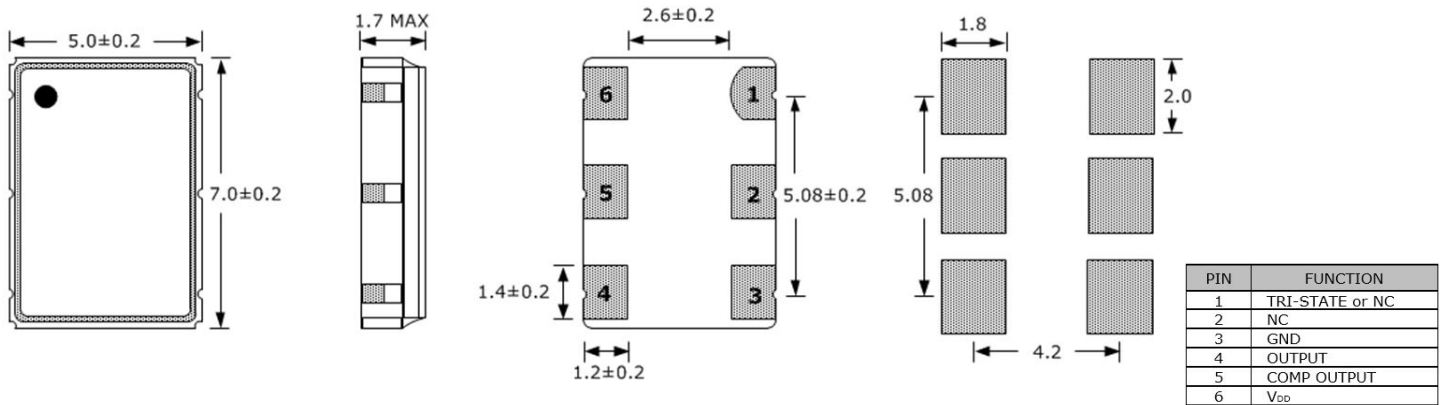

**Test Circuit (LVDS)**

**Waveform (LVDS)**

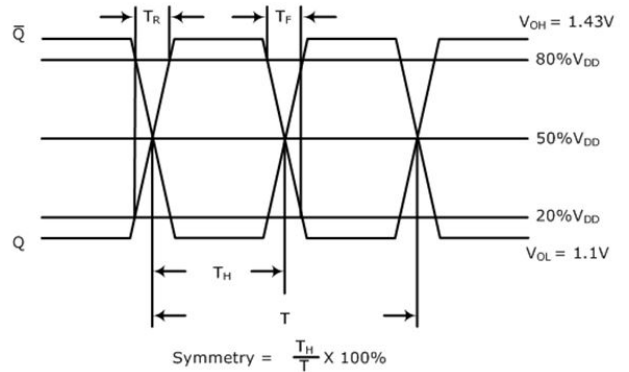
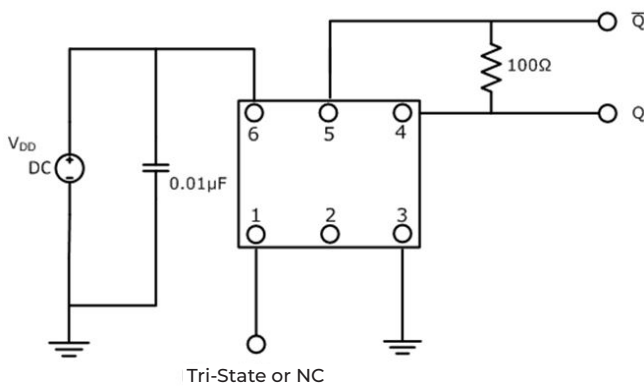

**Typical Phase Noise Performance (Measured By Agilent E5052A)**

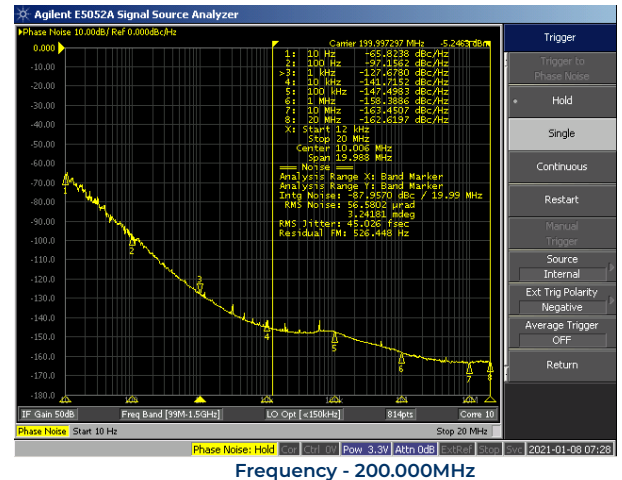
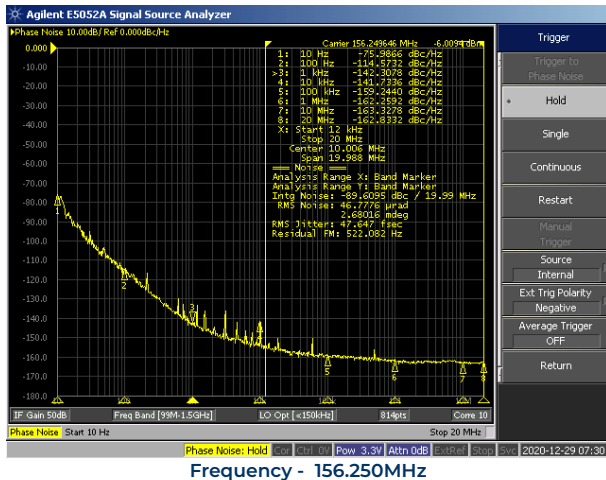

**Reflow Profile**

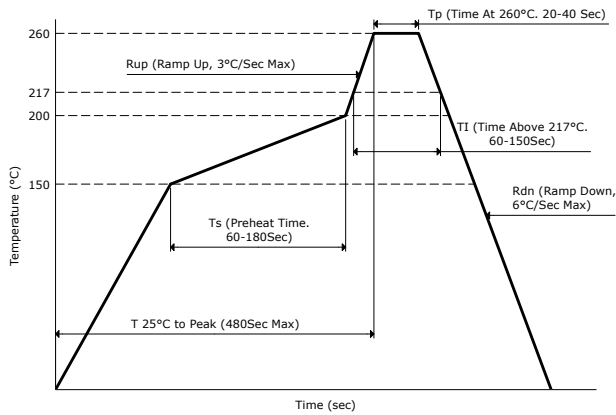

**Part Marking**

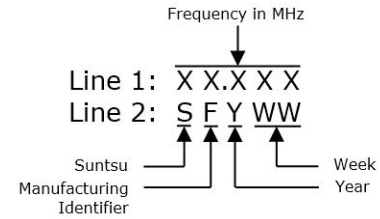

**Tape And Reel Dimensions**

All dimensions are in millimeters (mm) unless otherwise noted. Drawings are not to scale.

1,000pcs/Reel

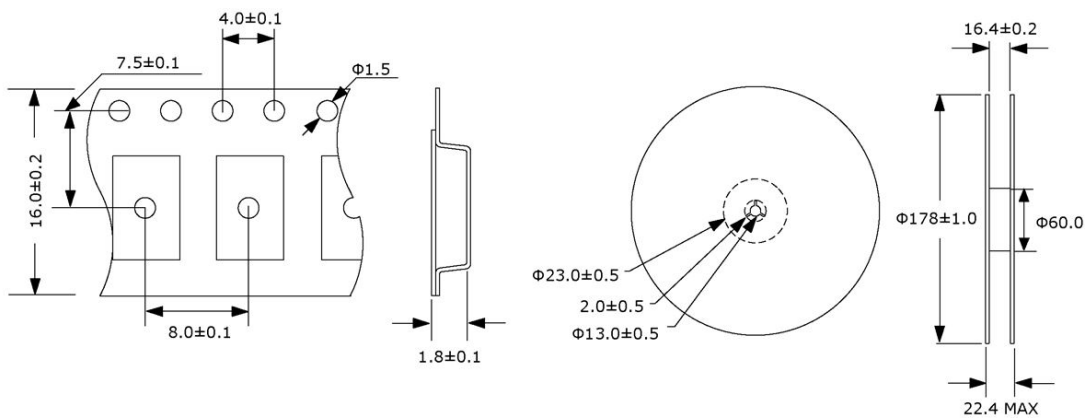

**Environmental Specifications**

Temperature Cycling	MIL-STD-883, Method 1010, Condition B
Fine Leak Test	MIL-STD-883, Method 1014, Condition A
Gross Leak Test	MIL-STD-883, Method 1014, Condition C
Solderability	MIL-STD-883, Method 2003
Moisture Sensitivity	J-STD-020, MSL 1

**Mechanical Specifications**

Mechanical Shock	MIL-STD-202, Method 213, Condition B
Vibration	MIL-STD-883, Method 2007, Condition A
Moisture Resistance	MIL-STD-883, Method 1004
Resistance to Solvents	MIL-STD-202, Method 215
Resistance to Soldering Heat	MIL-STD-202, Method 210, Condition K