

Features
<ul style="list-style-type: none"> ±20ppm (Frequency Stability) Available Low Phase Noise and Jitter Performance Tape and Reel

Applications
<ul style="list-style-type: none"> High Definition TV Avionics Low Phase Signal Sources Test and Measurement Equipment

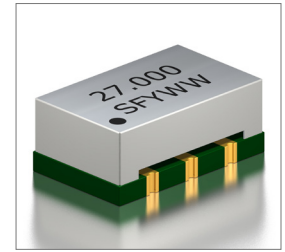

Part Numbering Guide

SVC F6 C 3 A 48 B 2 - 27.000M

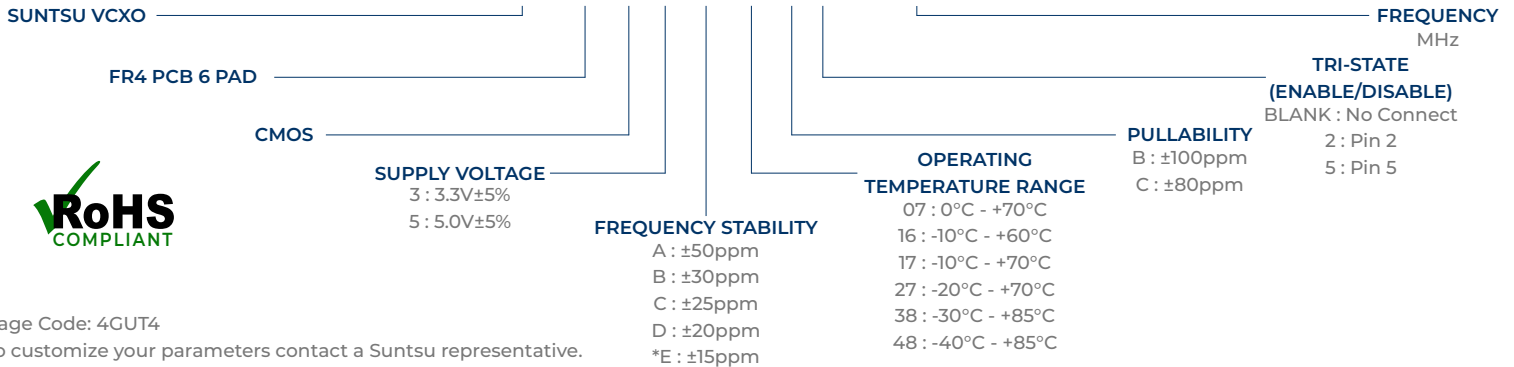

Cage Code: 4GUT4

To customize your parameters contact a Suntsu representative.

* For frequency stability option E contact a Suntsu representative.

Electrical Parameters	Units	Minimum	Typical	Maximum	Remarks
Frequency Range	MHz	10		250	~160MHz at 5.0V
Frequency Stability (Includes Initial Tolerance at 25°C, Frequency Stability over Operating Temperature, Output Load Change, Supply Voltage Change, and First Year Aging at 25°C.)	ppm	-20		20	See part numbering guide for options.
Operating Temperature	°C	-40		85	See part numbering guide for options.
Storage Temperature	°C	-45		90	
Supply Voltage (V _{DD}) 3.3V Option	V	3.135	3.3	3.465	
Supply Voltage (V _{DD}) 5.0V Option	V	4.750	5.0	5.250	See part numbering guide for options.
Current (I _{DD}) 3.3V Option	mA			40	
Current (I _{DD}) 5.0V Option	mA			60	
Current Voltage (V _c) 3.3V Option	V	0		3.3	
Current Voltage (V _c) 5.0V Option	V	0		5.0	
Pullability	ppm	±50		±100	See part numbering guide for options.
Linearity	%			10	
Output Load (CMOS)	pF			15	
Output Logic HIGH Level (V _{OH})	V	0.9*V _{DD}			
Output Logic LOW Level (V _{OL})	V			0.1*V _{DD}	
Rise (T _R) And Fall (T _F) Time	ns			3	
Symmetry (Duty Cycle)	%	45	50	55	
Input Impedance	kΩ			51	
Modulation Bandwidth	kHz	10			@-3dB
Start-Up Time	ms			10	
Phase Jitter (12KHz ~ 20MHz)	ps			1	

Outline Drawing & Land Pattern

All dimensions are in millimeters (mm) unless otherwise noted. Drawings are not to scale.

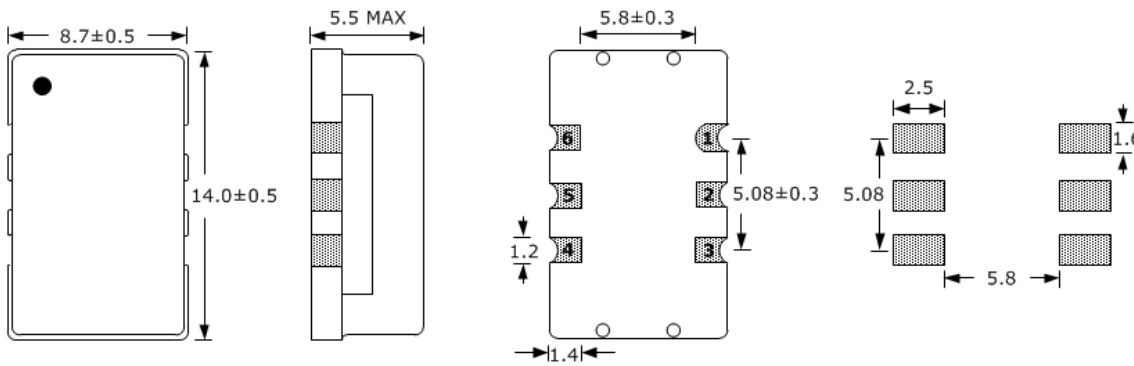

PIN	FUNCTION
1	VOLTAGE CONTROL
2	TRI-STATE or NC
3	GND
4	OUTPUT
5	TRI-STATE or NC
6	V _{DD}

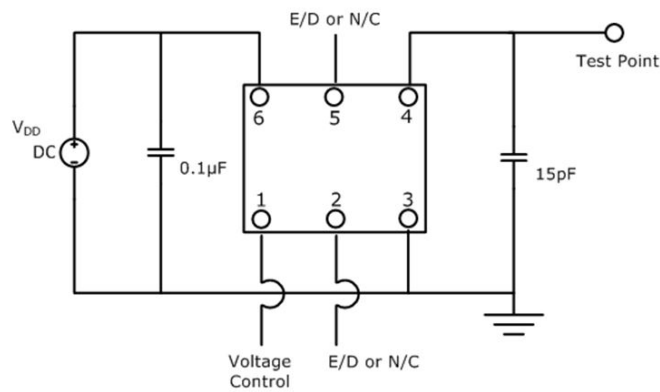
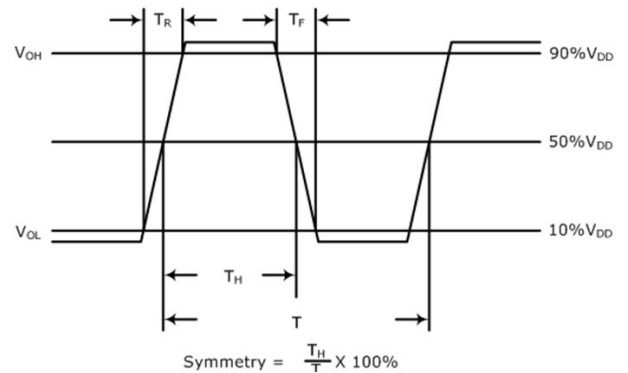
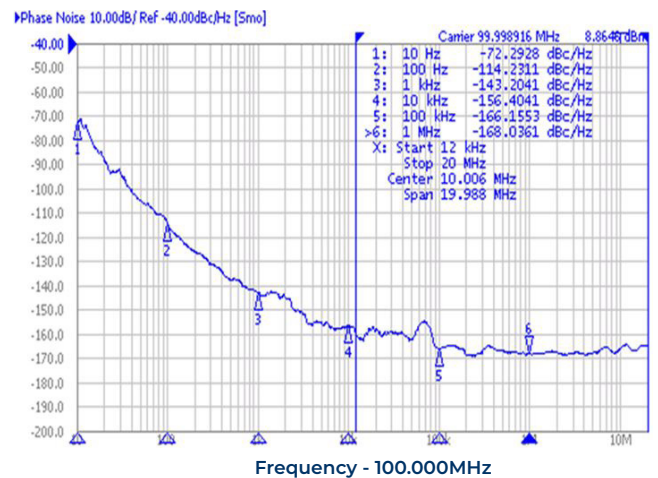
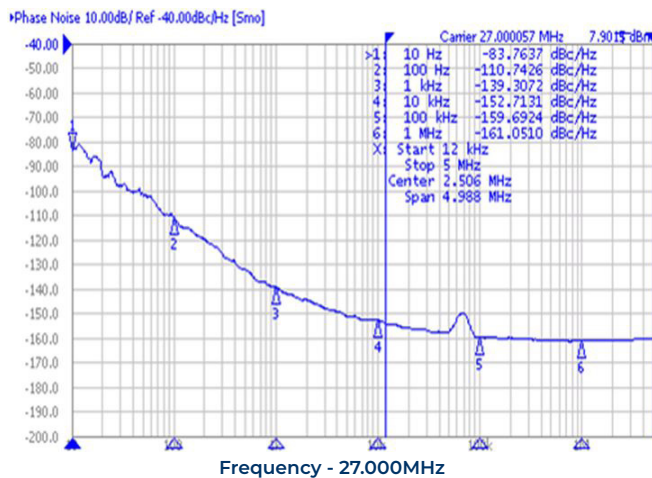
Test Circuit (CMOS)

Waveform (CMOS)

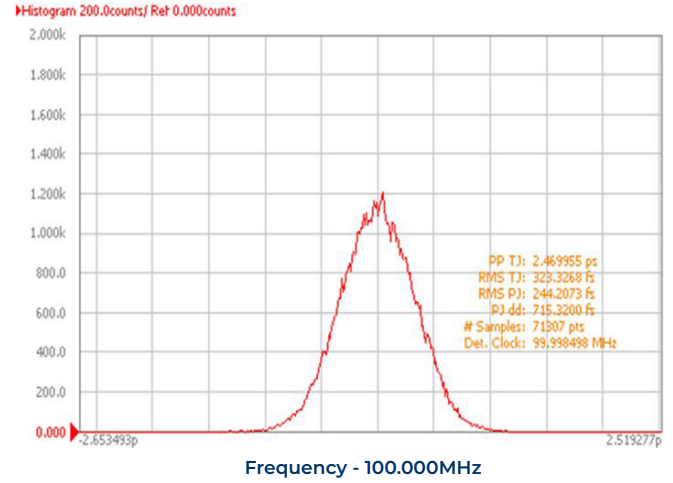
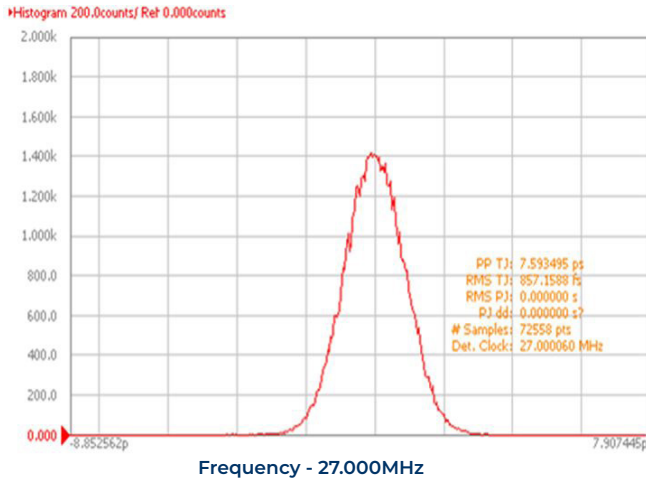
Typical Phase Noise Performance (Measured By Agilent E5052A)

Typical Jitter Performance (Measured By Agilent E5052A)

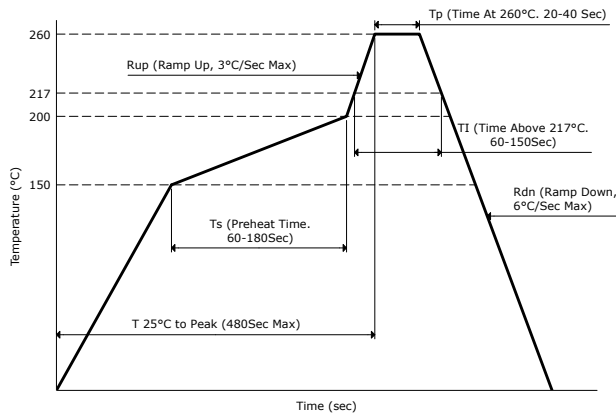

Reflow Profile



Part Marking

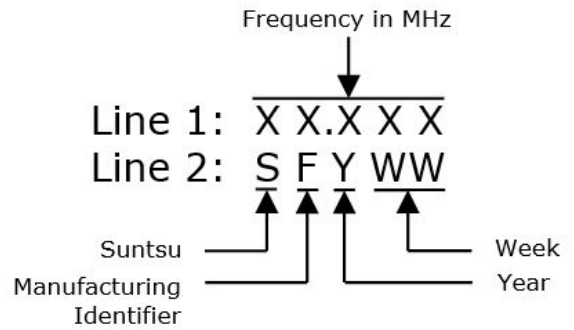

Tape And Reel Dimensions

All dimensions are in millimeters (mm) unless otherwise noted. Drawings are not to scale.

500pcs/Reel

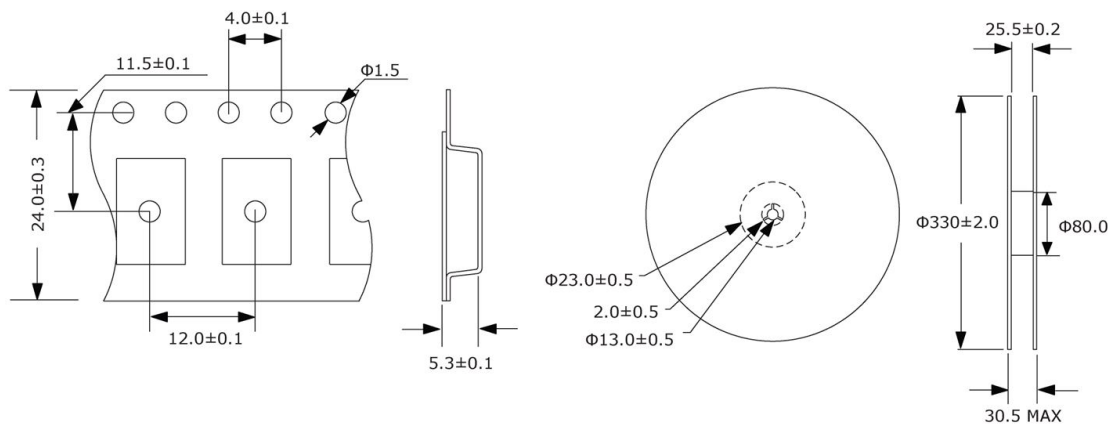

Environmental Specifications		Mechanical Specifications	
Temperature Cycling	MIL-STD-883, Method 1010, Condition B	Mechanical Shock	MIL-STD-202, Method 213, Condition B
Fine Leak Test	MIL-STD-883, Method 1014, Condition A	Vibration	MIL-STD-883, Method 2007, Condition A
Gross Leak Test	MIL-STD-883, Method 1014, Condition C	Moisture Resistance	MIL-STD-883, Method 1004
Solderability	MIL-STD-883, Method 2003	Resistance to Solvents	MIL-STD-202, Method 215
Moisture Sensitivity	J-STD-020, MSL 1	Resistance to Soldering Heat	MIL-STD-202, Method 210, Condition K