

Features
• ± 20 ppm (Frequency Stability) Available
• Standard Full Size Package
• CMOS/TTL Compatible
• Fundamental or PLL (Phase Lock Loop) Available

Applications
• Phase Locked Loops Circuit
• Synthesizers
• Base Stations

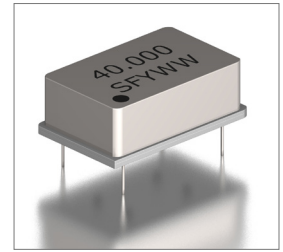

Part Numbering Guide

SVC FS C 3 A 48 A - 40.000M

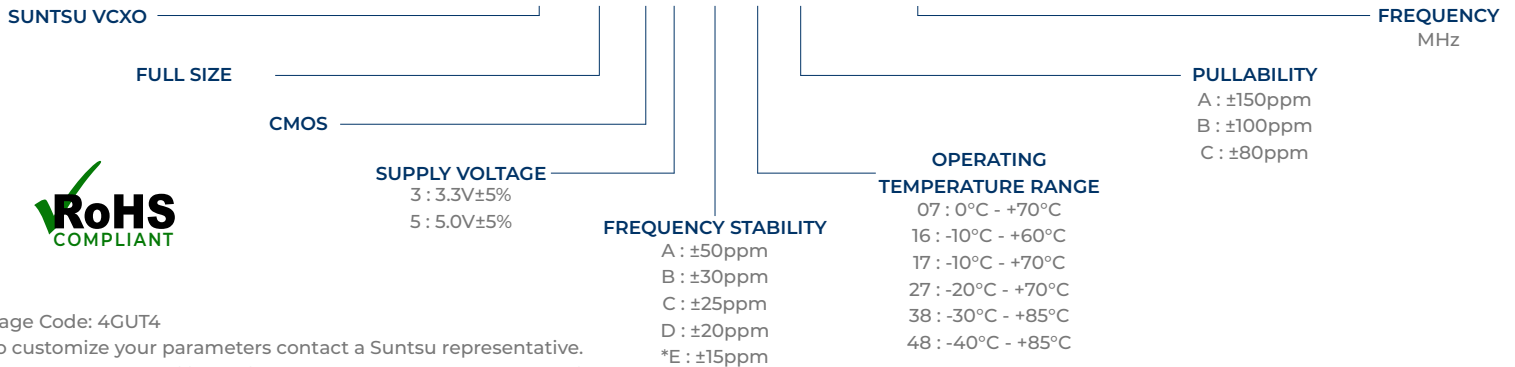

Cage Code: 4GUT4

To customize your parameters contact a Suntsu representative.

* For frequency stability option E contact a Suntsu representative.

Electrical Parameters	Units	Minimum	Typical	Maximum	Remarks
Frequency Range	MHz	1		160	
Frequency Stability (Includes Initial Tolerance at 25°C, Frequency Stability over Operating Temperature, Output Load Change, Supply Voltage Change, and First Year Aging at 25°C.)	ppm	-20		20	See part numbering guide for options.
Operating Temperature	°C	-40		85	See part numbering guide for options.
Storage Temperature	°C	-55		125	
Supply Voltage (V _{DD}) 3.3V Option	V	3.135	3.3	3.465	Available with AT-Cut Fundamental and PLL.
Supply Voltage (V _{DD}) 5.0V Option	V	4.750	5.0	5.250	Only available with AT-Cut Fundamental.
Current (I _{DD}) 3.3V Option	mA			40	
Current (I _{DD}) 5.0V Option	mA			50	
Current Voltage (V _C) 3.3V Option	V	0.3		3.0	
Current Voltage (V _C) 5.0V Option	V	0.5		4.5	
Pullability	ppm	±50	±100	±150	See part numbering guide for options.
Linearity	%			10	
Output Load (CMOS)	pF			15	
Output Load (TTL)	TTL			10	
CMOS Output Logic HIGH (V _{OH})	V	0.9*V _{DD}			
CMOS Output Logic LOW (V _{OL})	V			0.1*V _{DD}	
TTL Output Logic HIGH (V _{OH})	V	2.4			
TTL Output Logic LOW (V _{OL})	V			0.4	
Rise (T _r) And Fall (T _f) Time	ns			5	
Symmetry (Duty Cycle)	%	45	50	55	
Start-Up Time	ms			10	
Phase Jitter (12KHz ~ 20MHz)	ps			1	AT-Cut Fundamental
Phase Jitter (12KHz ~ 20MHz)	ps			5	PLL (Phase Lock Loop)

Outline Drawing & Part Marking

All dimensions are in millimeters (mm) unless otherwise noted. Drawings are not to scale.

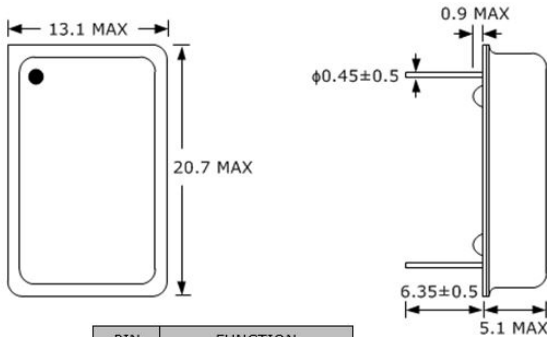

PIN	FUNCTION
1	VOLTAGE CONTROL
7	GND
8	OUTPUT
14	V _{DD}

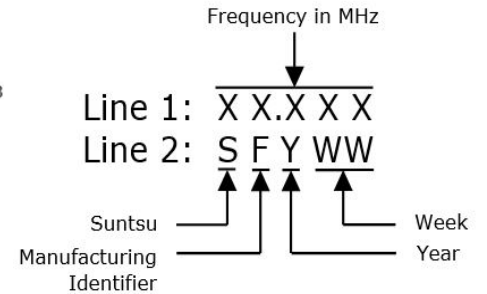
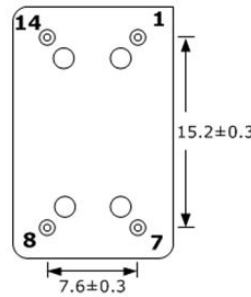

Test Circuit (CMOS/TTL Compatible)

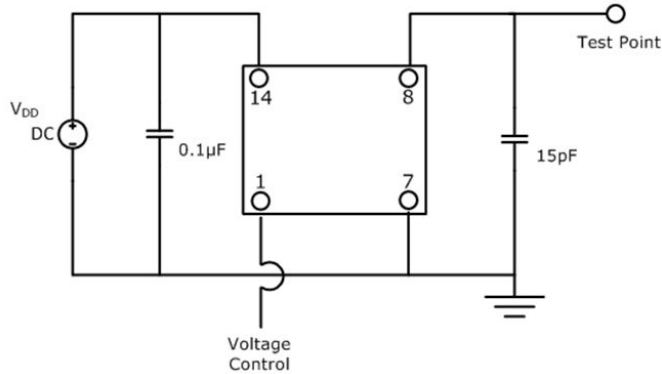

Waveform (CMOS/TTL Compatible)

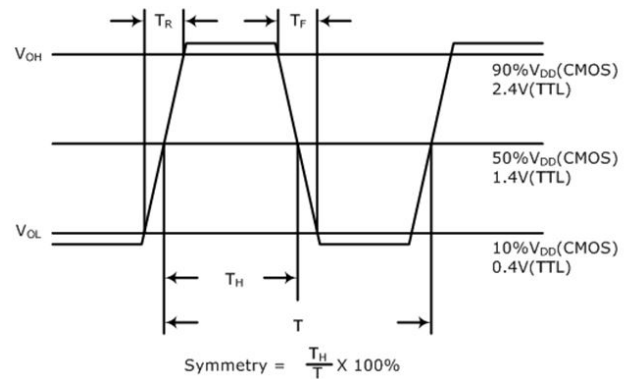

Typical Phase Noise and Jitter Performance (Measured By Agilent E5052A)

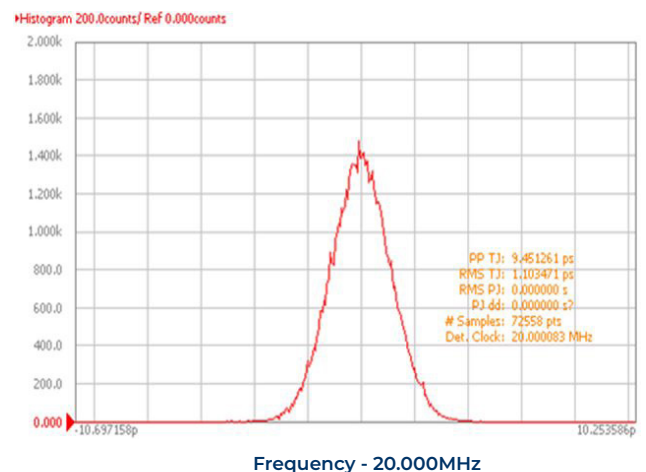
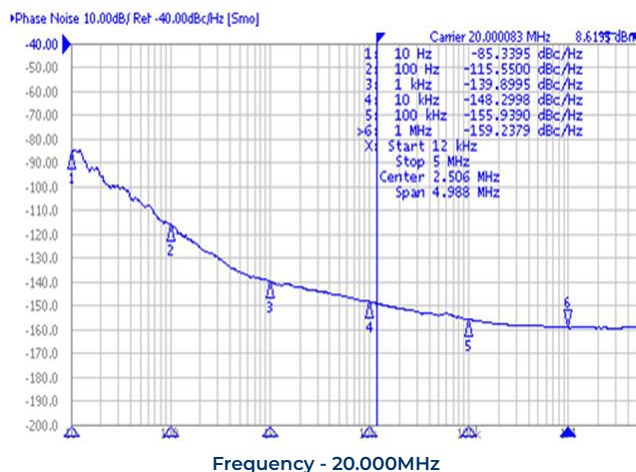

Environmental Specifications		Mechanical Specifications	
Temperature Cycling	MIL-STD-883, Method 1010, Condition B	Mechanical Shock	MIL-STD-202, Method 213, Condition B
Fine Leak Test	MIL-STD-883, Method 1014, Condition A	Vibration	MIL-STD-883, Method 2007, Condition A
Gross Leak Test	MIL-STD-883, Method 1014, Condition C	Moisture Resistance	MIL-STD-883, Method 1004
Solderability	MIL-STD-883, Method 2003	Resistance to Solvents	MIL-STD-202, Method 215
Moisture Sensitivity	J-STD-020, MSL 1	Resistance to Soldering Heat	MIL-STD-202, Method 210, Condition K