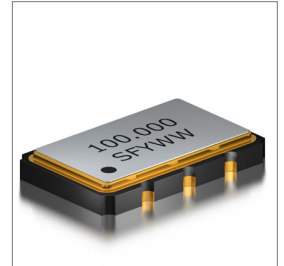
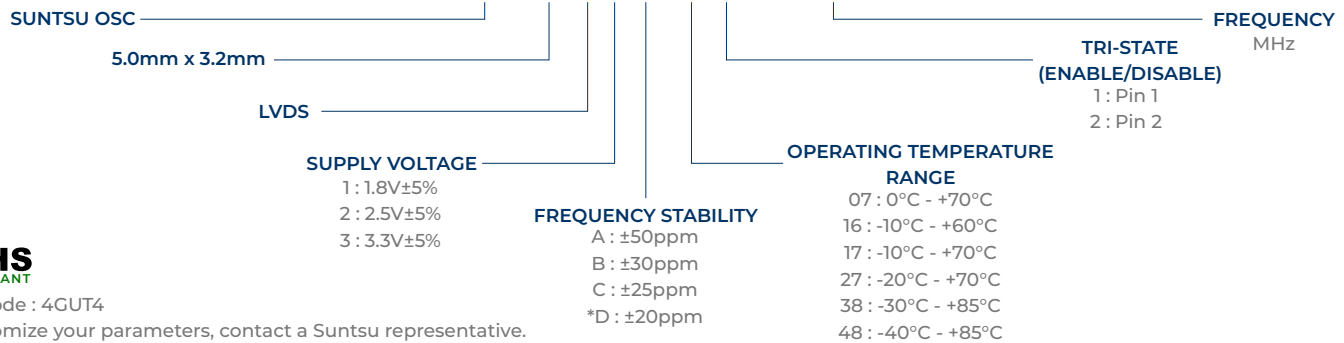

Features
<ul style="list-style-type: none"> ±20ppm (Frequency Stability) Available Ceramic Package LVDS Tape and Reel

Applications
<ul style="list-style-type: none"> Fiber Channel Gigabit Ethernet PCI Express

Part Numbering Guide
SXO 53 L 3 A 48 1 - 100.000M

Cage Code : 4GUT4

To customize your parameters, contact a Suntsu representative.

* For Frequency stability option D, contact a Suntsu representative.

Electrical Parameters	Units	Minimum	Typical	Maximum	Remarks
Frequency Range	MHz	80		212.500	
Frequency Stability (Includes Initial Tolerance at 25°C, Frequency Stability over Operating Temperature, Output Load Change, Supply Voltage Change, and First Year Aging at 25°C.)	ppm	-20		+20	See part numbering guide for options
Operating Temperature	°C	-40		+85	See part numbering guide for options
Storage Temperature	°C	-55		+125	
Supply Voltage (V _{DD}) - 1.8V Option	V	1.71	1.8	1.89	
Supply Voltage (V _{DD}) - 2.5V Option	V	2.375	2.5	2.625	
Supply Voltage (V _{DD}) - 3.3V Option	V	3.135	3.3	3.465	
Current (I _{DD}) - 1.8V Option	mA			40	
Current (I _{DD}) - 2.5V Option	mA			50	
Current (I _{DD}) - 3.3V Option	mA			60	
Output Load (LVDS)	Ω			100	
Output Logic Levels High (V _{OH})	V		1.43	1.6	
Output Logic Levels Low (V _{OL})	V	0.9	1.1		
Differential Output Voltage (V _{OD})	mV	247	330	454	
Differential Output Error (pV _{OD})	mV			50	
Offset Voltage (V _{OS})	V	1.125	1.250	1.375	
Offset Error (pV _{OS})	mV			50	
Rise (TR) and Fall (TF) Time	ns		0.4	0.8	
Symmetry (Duty Cycle)	%	45	50	55	
Tri-State Input Voltage - Enable	V	0.7*V _{DD}			No Connection
Tri-State Input Voltage - Disable	V			0.3*V _{DD}	
Start-Up Time	ms			10	
Phase Jitter (12kHz ~ 20MHz)	ps		0.4	1	

Outline Drawing & Land Pattern

All dimensions are in millimeters (mm) unless otherwise noted. Drawings are not to scale.

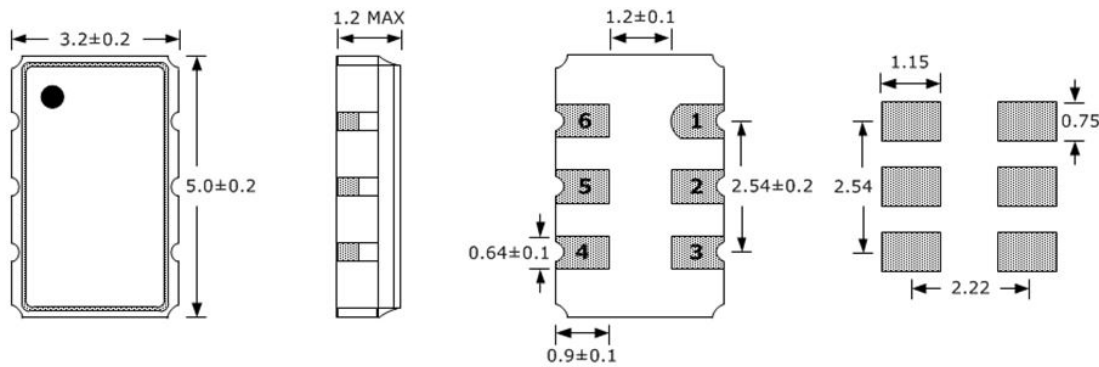

PIN	FUNCTION
1	TRI-STATE or NC
2	TRI-STATE or NC
3	GND
4	OUTPUT
5	COMP OUTPUT
6	V _{DD}

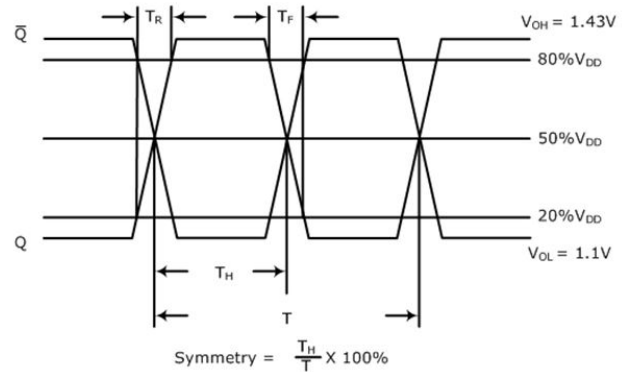
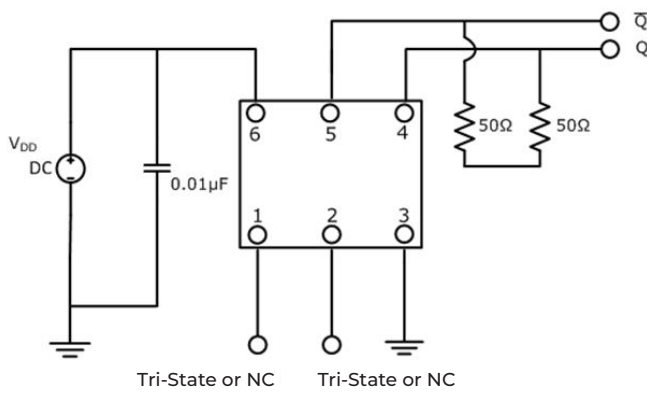
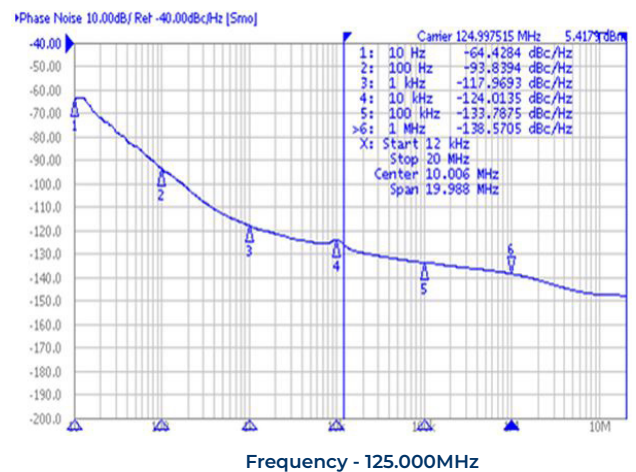
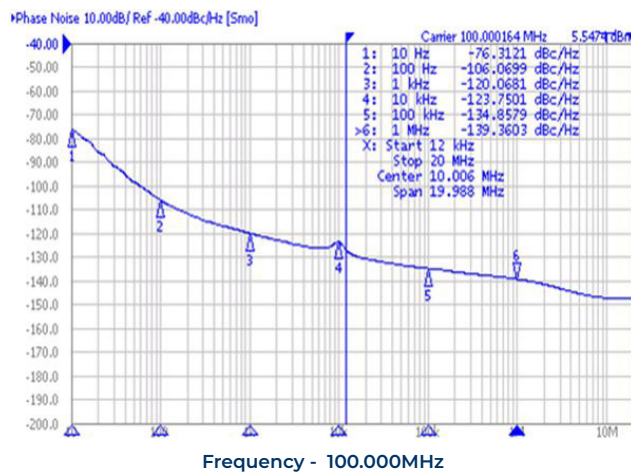
Test Circuit (LVDS)
Waveform (LVDS)

Typical Phase Noise Performance (Measured By Agilent E5052A)

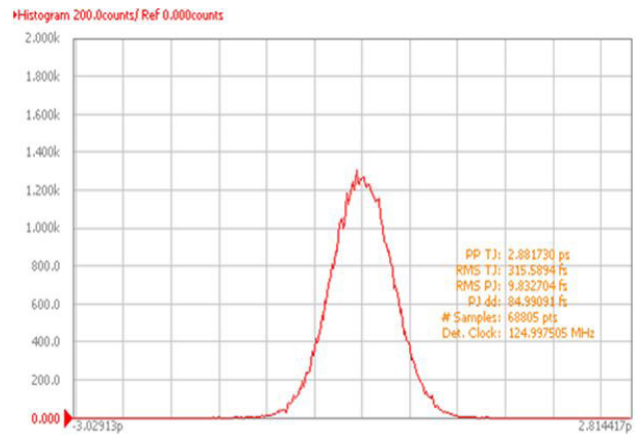
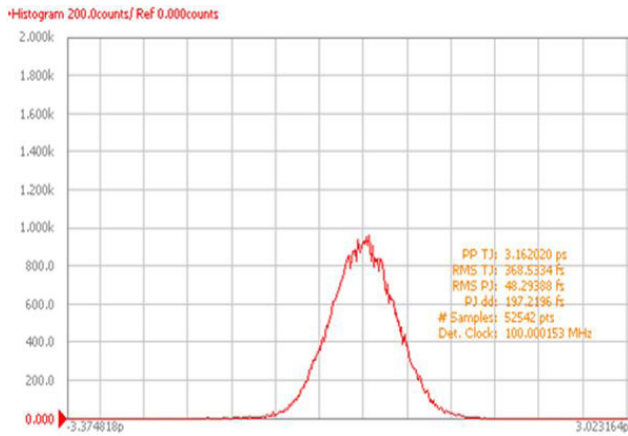
Typical Jitter Performance (Measured By Agilent E5052A)

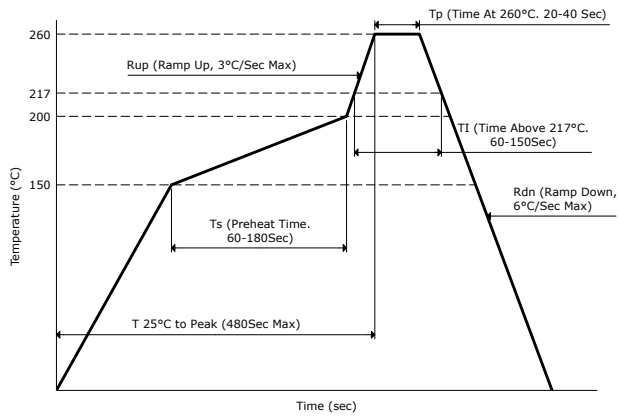

Reflow Profile



Part Marking

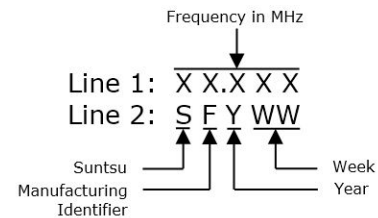

Tape And Reel Dimensions

All dimensions are in millimeters (mm) unless otherwise noted. Drawings are not to scale.

1,000pcs/Reel

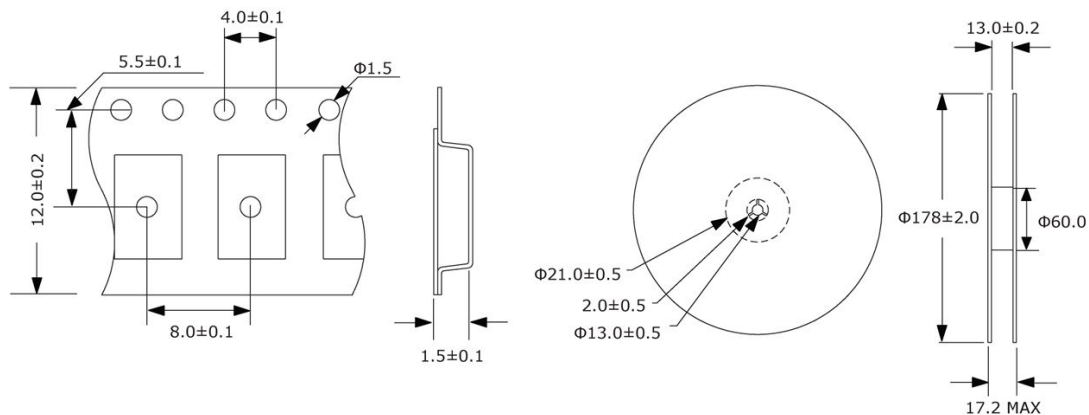

Environmental Specifications		Mechanical Specifications	
Temperature Cycling	MIL-STD-883, Method 1010, Condition B	Mechanical Shock	MIL-STD-202, Method 213, Condition B
Fine Leak Test	MIL-STD-883, Method 1014, Condition A	Vibration	MIL-STD-883, Method 2007, Condition A
Gross Leak Test	MIL-STD-883, Method 1014, Condition C	Moisture Resistance	MIL-STD-883, Method 1004
Solderability	MIL-STD-883, Method 2003	Resistance to Solvents	MIL-STD-202, Method 215
Moisture Sensitivity	J-STD-020, MSL 1	Resistance to Soldering Heat	MIL-STD-202, Method 210, Condition K